





Hendrex Pagdilao

graphicdesigner | 3Ddesigner | programmer



+63 967 270 9405



hendrexpagdilao@gmail.com



www.hendrexpagdilao.com



www.linkedin.com/in/hendrex-pagdilao-6a362677/



www.behance.net/hendrexpagdilao



Pavia St. Pob. East, Rosario, La Union, Philippines

OBJECTIVES

Seeking a challenging position in the art field to contribute my design skills and experience.

EDUCATION

Bachelor of Science in Information Technology

Saint Louis College

Carlattan, San Fernando, La Union Philippines

2003-2007

SKILLS

3D Studio Max

Autocad

Adobe Photoshop

Adobe Illustrator

Adobe Indesign

Adobe Premier

Corel Draw

HTML/CSS/PHP

Problem Solving

Time Management

Detail-Orientation

Adaptability

Communication

Computer Literacy

WORK EXPERIENCE

Drafter

NJ WORKS PTE. LTD.

December 2021 - November 2022

Interior Designer

PERFORM INDUSTRIES PTE. LTD.

April 2021 - November 2022

2D/3D Designer / Project Executive

WOODLAB PTE. LTD.

December 2018 - April 2021

Interior Designer

DMX PROJECTS PTE. LTD.

November 2017 - November 2018

Programmer / Project Engineer

EETECH INNOVATION TRADING AND

ELECTRONICS SERVICES

July 2016 - August 2017

Graphic Artist

FAMILY SHOPPERS UNLIMITED INC.

October 2012 - July 2016

Graphic Artist

I-CYBERWORLDS BIZ INC.

February 2011 - March 2012

Graphic Designer

BAN KEE TRADING INC.

July 2007 - January 2011

Logistic Staff (Internship)

COCA-COLA BOTTLERS OF THE PHILIPPINES

April 2006 - May 2006



CORPORATE DESIGN

01 SHOP DRAWING

Location:
MCI (Ministry of Communications & Information)

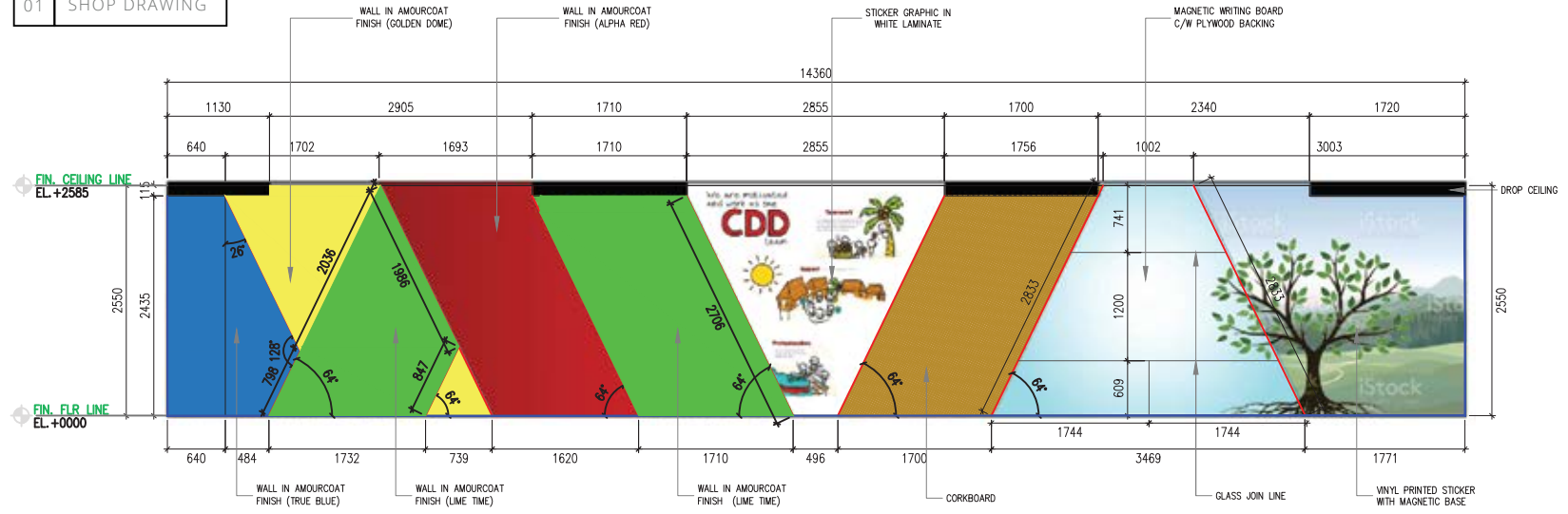

02 SITE PHOTO

ELE FRONT ELEVATION
J13 SCALE 1 : 50



Location:
MCI (Ministry of Communications & Information)

01 SHOP DRAWING

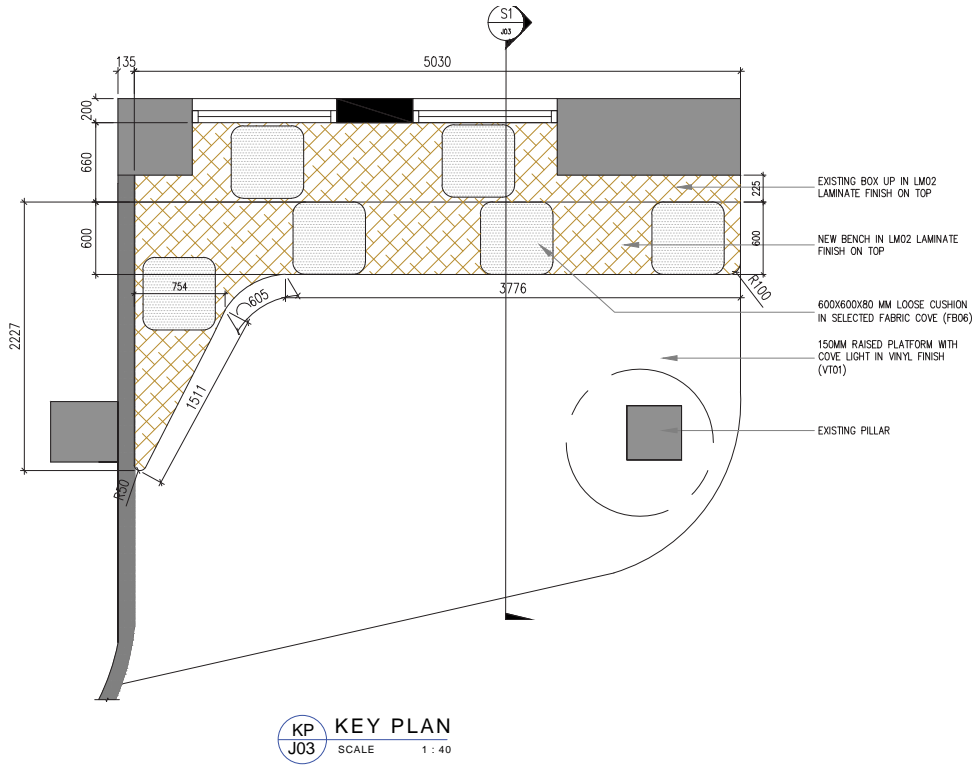

02 SITE PHOTO

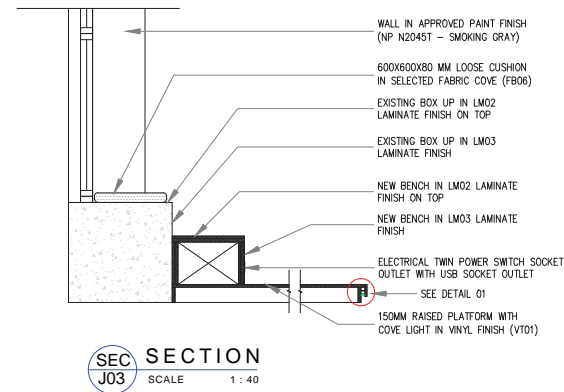
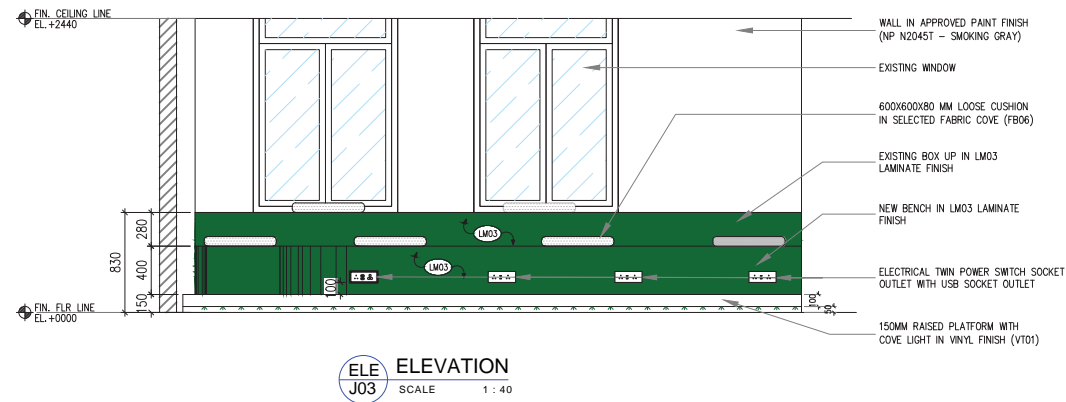

Location:
MCI (Ministry of Communications & Information)

01 SHOP DRAWING



ELE ELEVATION
SCALE 1:40

02 SITE PHOTO



01 SHOP DRAWING

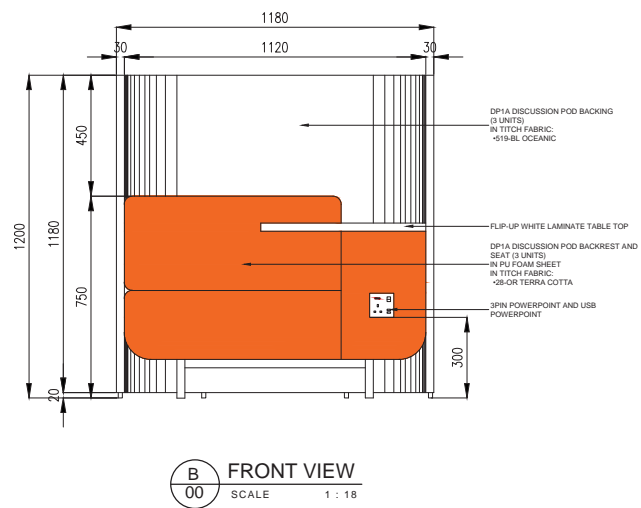
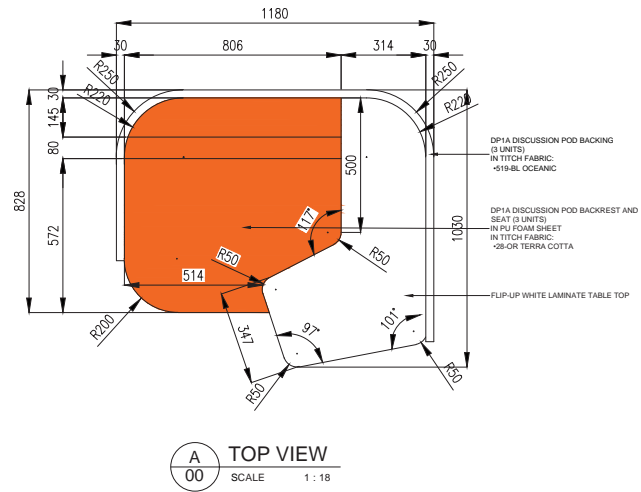

Location:
MCI (Ministry of Communications & Information)

02 SITE PHOTO

01 SHOP DRAWING

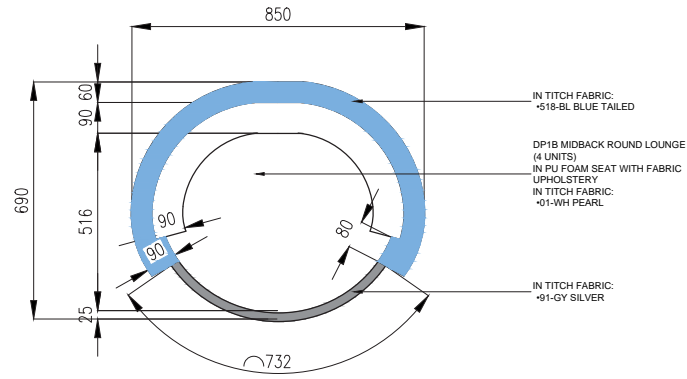

A TOP VIEW
00 SCALE 1 : 16

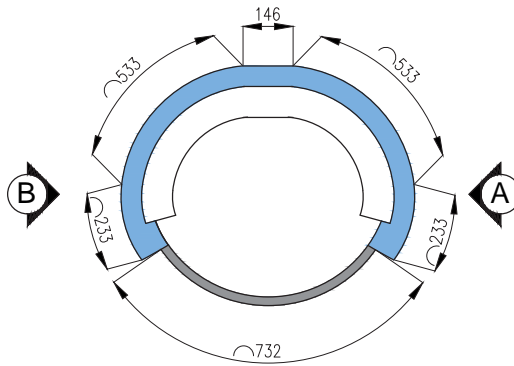

B TOP VIEW
00 SCALE 1 : 16

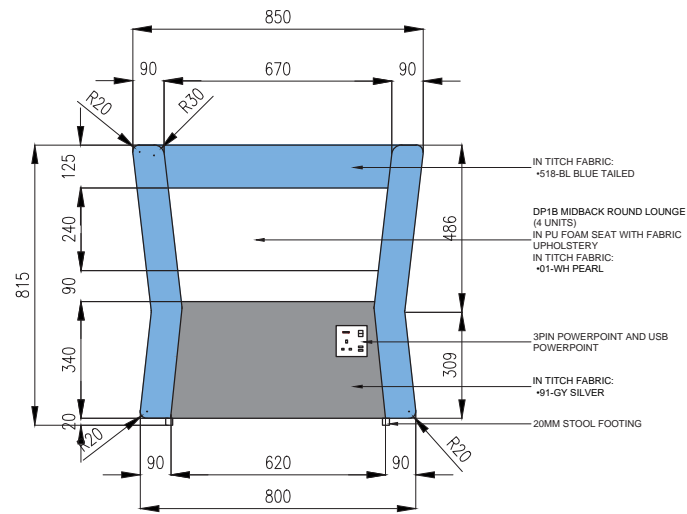

D FRONT VIEW
00 SCALE 1 : 16

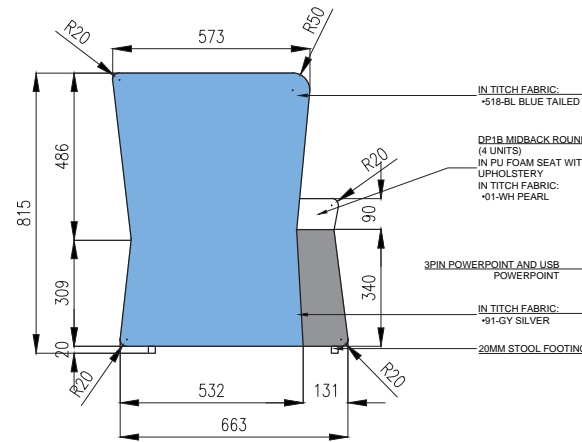

E ELEVATION B
00 SCALE 1 : 16

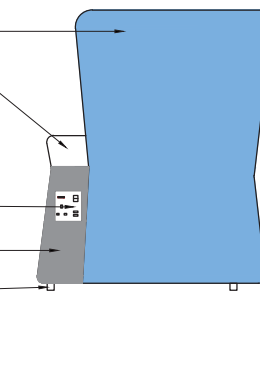

F ELEVATION A
00 SCALE 1 : 16

IN TITCH FABRIC:
-518-BL BLUE TAILED

DP1B MIDBACK ROUND LOUNGE
(4 UNITS)

IN PU FOAM SEAT WITH FABRIC
UPHOLSTERY

IN TITCH FABRIC:
-01-WH PEARL

IN TITCH FABRIC:
-91-GY SILVER

IN TITCH FABRIC:
-518-BL BLUE TAILED

DP1B MIDBACK ROUND LOUNGE
(4 UNITS)

IN PU FOAM SEAT WITH FABRIC
UPHOLSTERY

IN TITCH FABRIC:
-01-WH PEARL

3PIN POWERPOINT AND USB
POWERPOINT

IN TITCH FABRIC:
-91-GY SILVER

20MM STOOL FOOTING

01 SHOP DRAWING

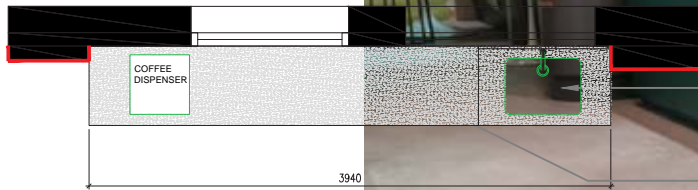

UNDERMOUNT SINK & TAP (SW01 & SW02)

40MM THK COUNTERTOP IN QUARTZ OTTO MARBLELINE GO 1607 IBIZA FINISH (ST01) WITH 80MM HT BACKPLASH

KP KEY PLAN
J07 SCALE 1 : 40

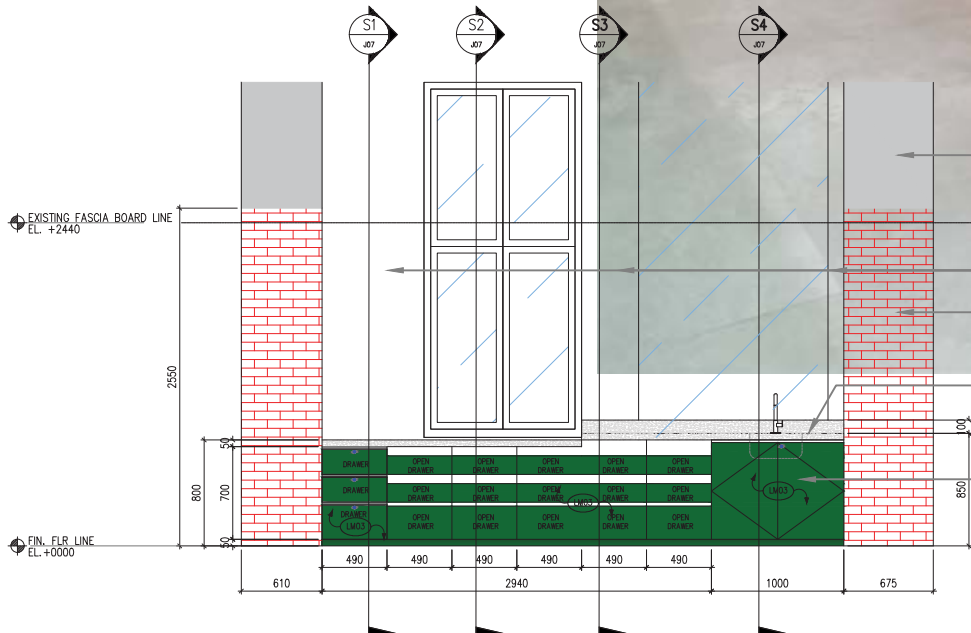

WALL IN SELECTED PAINT FINISH

WALL IN APPROVED PAINT FINISH (NP N2045T - SMOKING GRAY)

BRICK WALL FINISH BF01

40MM THK COUNTERTOP IN QUARTZ OTTO MARBLELINE GO 1607 IBIZA FINISH (ST01) WITH 80MM HT BACKPLASH

CABINET DOOR & DRAWER IN LM03 LAMINATE FINISH C/W MATCHING PVC EDGING/
ADJUSTABLE SHELF (25MM THK)/ LOCK SET AND INTERNAL IN LM01 LAMINATE FINISH

01 SITE PHOTO

ELE ELEVATION
J07 SCALE 1 : 40

Location:
MCI (Ministry of Communications & Information)



01 | SHOP DRAWING

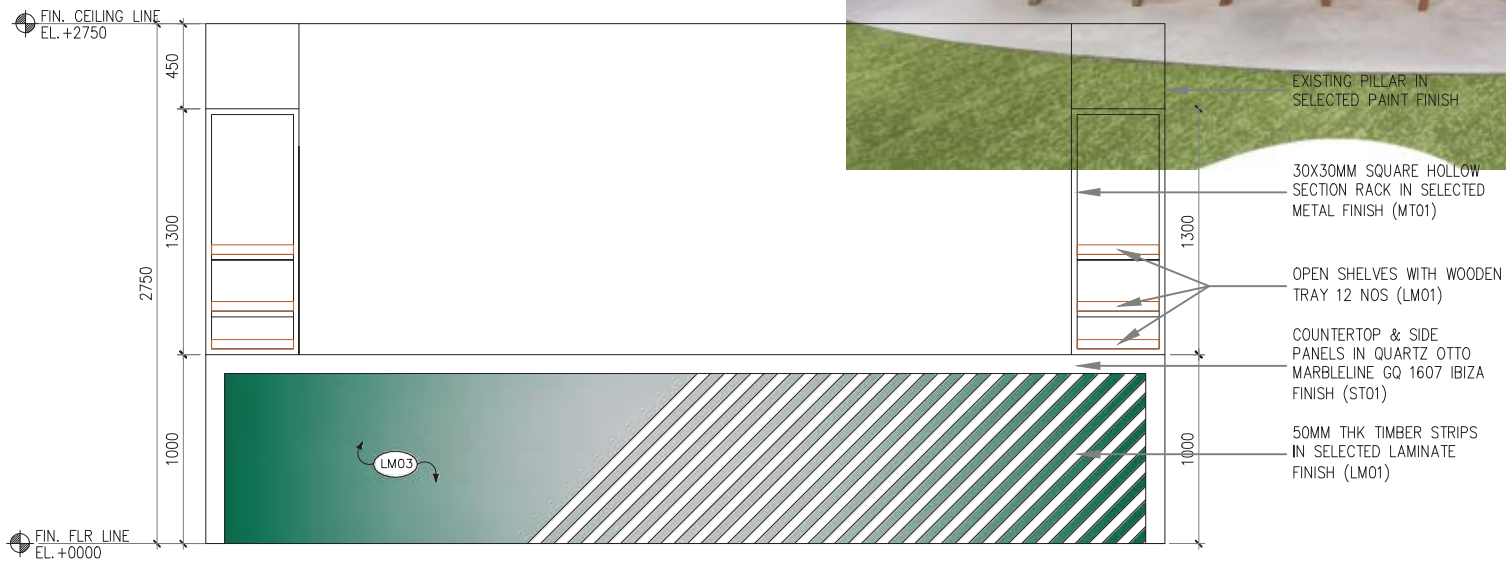

ELE
J06 | **ELEVATION A**
SCALE 1 : 40

Location:
MCI (Ministry of Communications & Information)



01 SHOP DRAWING

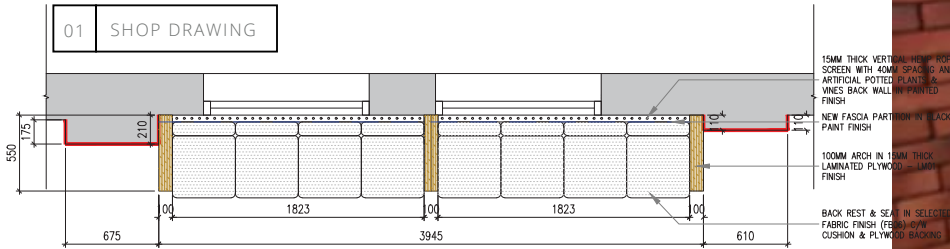

- 15MM THICK VERTICAL HEMP ROPE SCREEN WITH 40MM SPACING AND ARTIFICIAL POTTED PLANTS & VINES BACK WALL IN PAINTED FINISH
- NEW FASOIA PARTITION IN BLACK PAINT FINISH
- 100MM ARCH IN 18MM THICK LAMINATED PLYWOOD - LM01 FINISH
- BACK REST & SEAT IN SELECTED FABRIC FINISH (FB06) C/W CUSHION & PLYWOOD BACKING

KP KEY PLAN
J08 SCALE 1:30

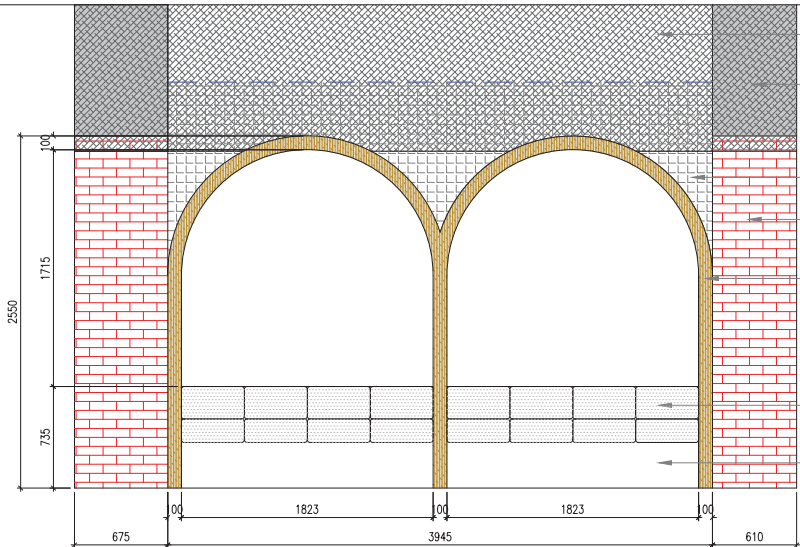

ELE ELEVATION
J08 SCALE 1:30

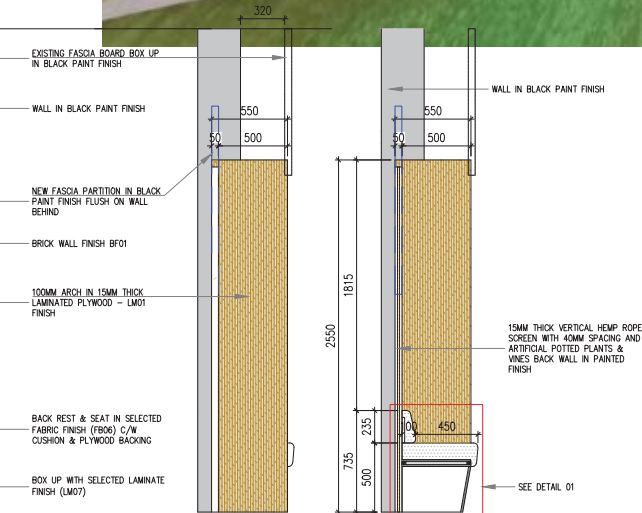

SEC SIDE VIEW
J08 SCALE 1:30

SEC SECTION
J08 SCALE 1:30

Location:
MCI (Ministry of Communications & Information)



01 | SHOP DRAWING

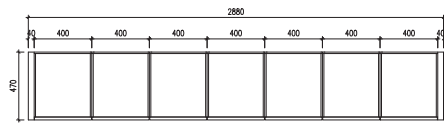

KP 114 KEY PLAN
SCALE 1 : 20

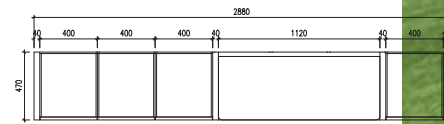

KP 114 KEY PLAN
SCALE 1 : 20

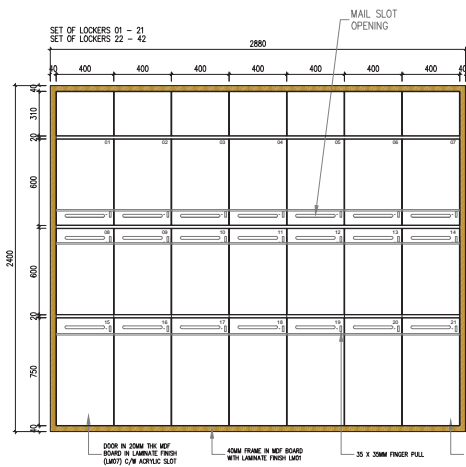

SEC 114 FRONT ELEVATION
SCALE 1 : 20

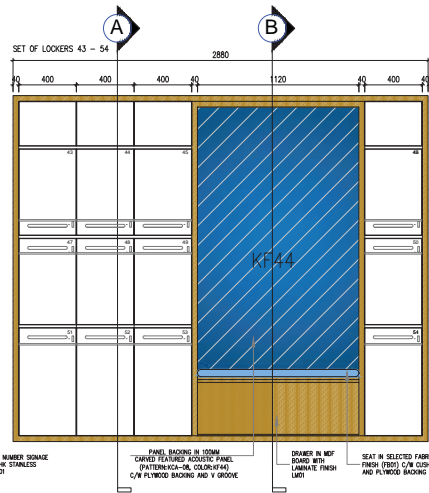

SEC 114 FRONT ELEVATION
SCALE 1 : 20

- DOOR IN 20MM THE MDF BOARD W/ LAMINATE FINISH (LMO7) C/W ACRYLIC SLOT
- 40MM FRAME IN MDF BOARD WITH LAMINATE FINISH (LMO7)
- 35 X 20MM FINGER PULL
- 250x25mm NUMBER SIGNAGE IN 2MM DIA STAINLESS STEEL W/01
- PANEL BACKING IN 100MM CARVED FEATHERED ACOUSTIC PANEL (PATTERN:SC-01, COLOUR:R44) C/W PLYWOOD BACKING AND V GROOVE
- DOORER IN MDF BOARD WITH LAMINATE FINISH (LMO7)
- SEAT IN SELECTED FABRIC FINISH (FROG) C/W CUSHION AND PLYWOOD BACKING

Location:
MCI (Ministry of Communications & Information)

01 SHOP DRAWING

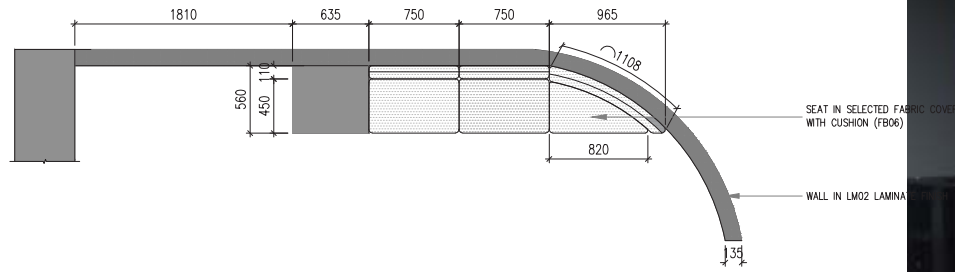

KP KEY PLAN
J02 SCALE 1 : 40

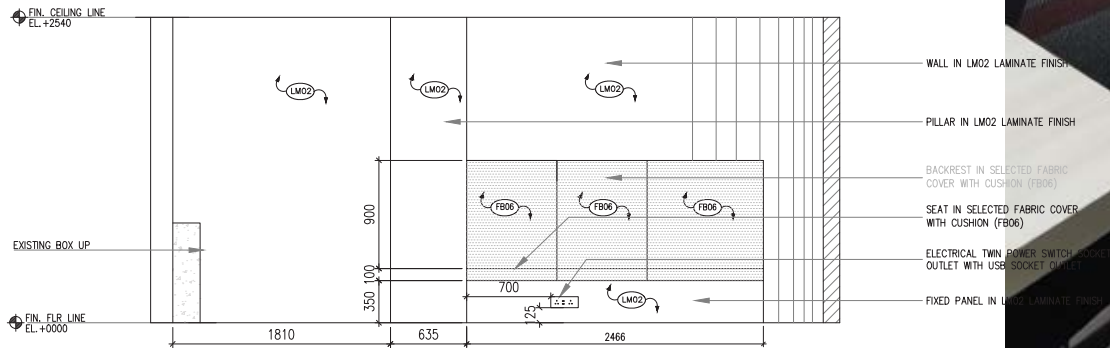

ELE ELEVATION
J02 SCALE 1 : 40



Location:
MCI (Ministry of Communications & Information)

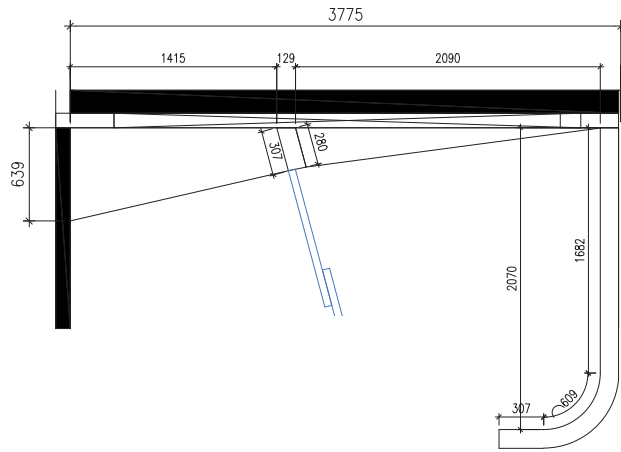

KP KEY PLAN
J10 SCALE 1 : 40

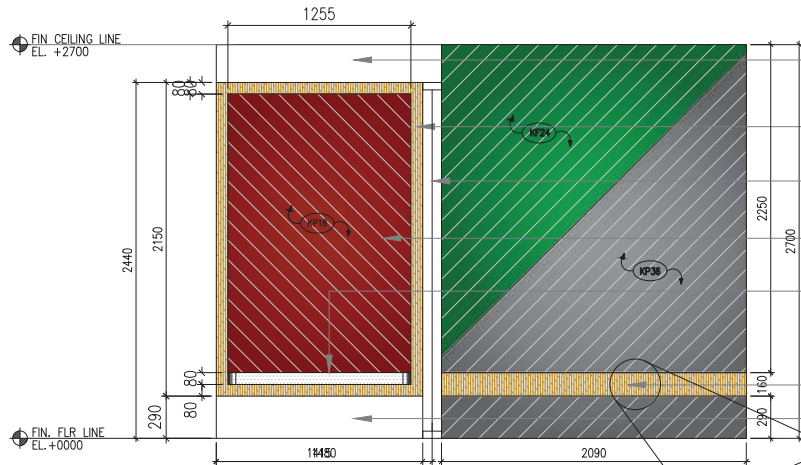

ELE ELEVATION
J10 SCALE 1 : 40

- WALL IN APPROVED PAINT FINISH (NP_N2045T - SMOKING GRAY)
- FRAME WITH LAMINATE (LM01)
- 100MM THK SINGLE GAZE BLACK FRAME GLASS WALL (P2)
- BACKING IN CARVED FEATURED ACOUSTIC PANEL (PATTERN:KCA-08, COLOR:KP18) C/W PLYWOOD BACKING AND V GROOVE
- SEAT IN SELECTED FABRIC COVER WITH CUSHION (FB06)
- LEDGE IN SELECTED LAMINATE FINISH (LM01)
- WALL IN APPROVED PAINT FINISH (NP_N2045T - SMOKING GRAY)

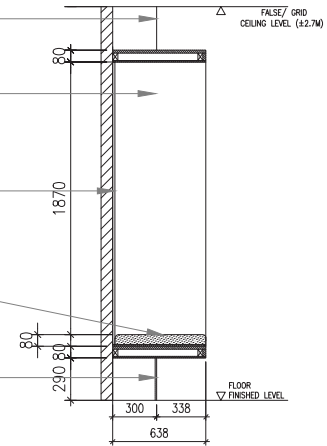

SEC SECTION
J10 SCALE 1 : 40

Location:
MCI (Ministry of Communications & Information)

01 SITE PHOTO

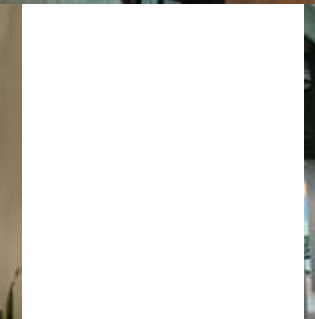



COMMERCIAL/ RESIDENTIAL DESIGN

2018 - 2022

COMMERCIAL DESIGN

Location:
FISHBALL STORY @ BUGIS JUNCTION #01 71/72, SINGAPORE

01 3D DRAWING



RESIDENTIAL DESIGN

Location:
FISHBALL STORY @ BUGIS JUNCTION #01 71/72, SINGAPORE

02 ACTUAL PHOTO

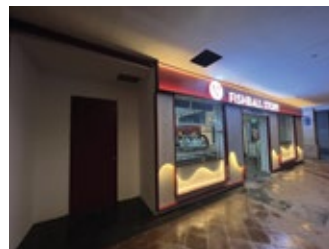

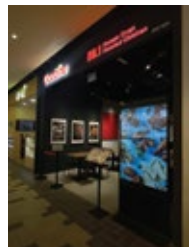

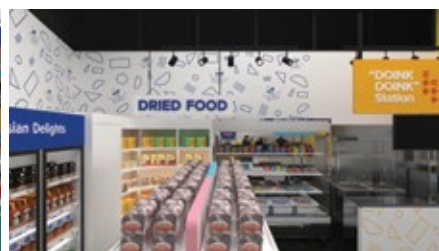

02 ACTUAL PHOTO



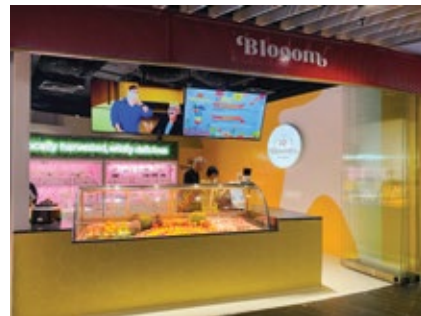

Location:
TORI-TEN @ KATONG i12, SINGAPORE

01 3D DRAWING



02 ACTUAL PHOTO



Location:
GREENDOT @ ANG MO KIO HUB #B2-36, SINGAPORE

01 3D DRAWING



02 ACTUAL PHOTO



Location:
GREENDOT @ PAYA LEBAR SQUARE #02-21, SINGAPORE

01 3D DRAWING



02 ACTUAL PHOTO

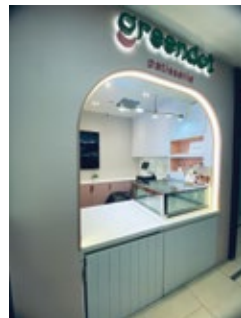
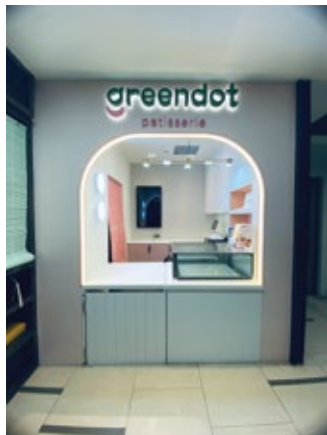

01 3D DRAWING



02 ACTUAL PHOTO





Location:
Novelty Techpoint @ 27 New Industrial Road

01 3D DRAWING

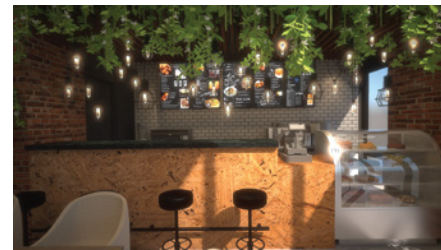
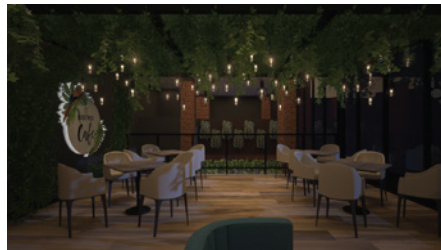



Location:
146, Changi Rd.

01 3D DRAWING



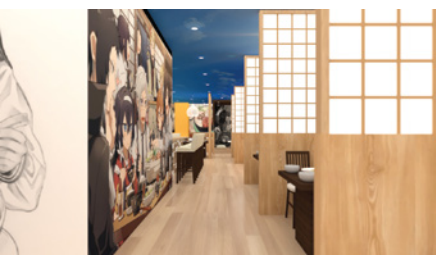









TRAVEL RETAIL DESIGN

2018 - 2021

01 LAY OUT PLAN

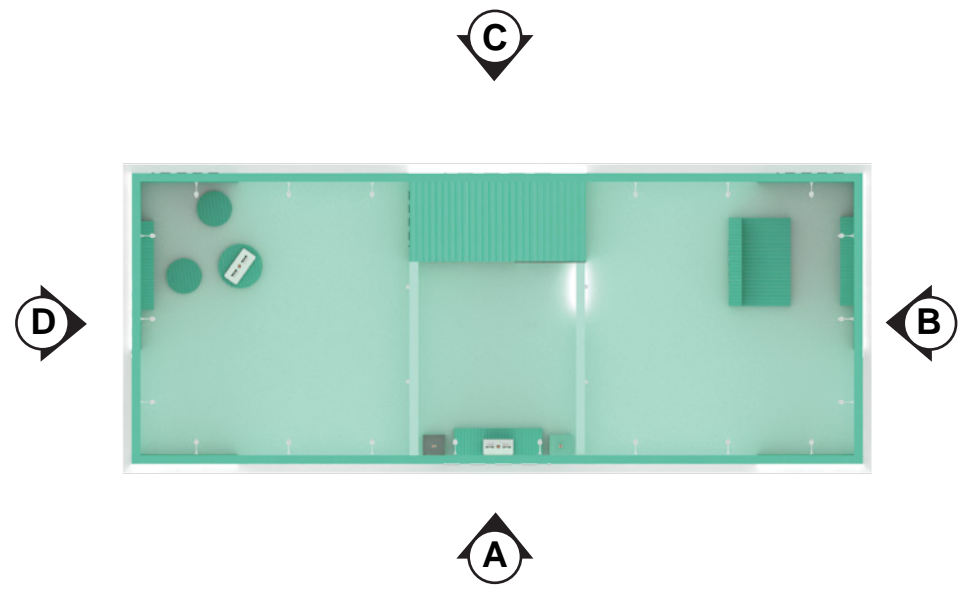

02 PERSPECTIVE VIEW





ELEVATION A



ELEVATION B



ELEVATION C



ELEVATION D

01 LAY OUT PLAN

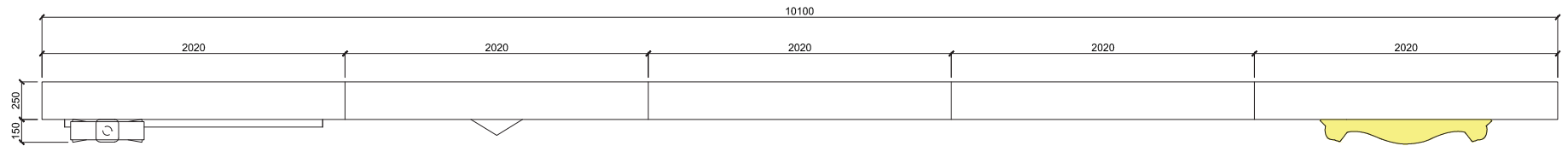

A TOP VIEW
01 / SCALE 1:35

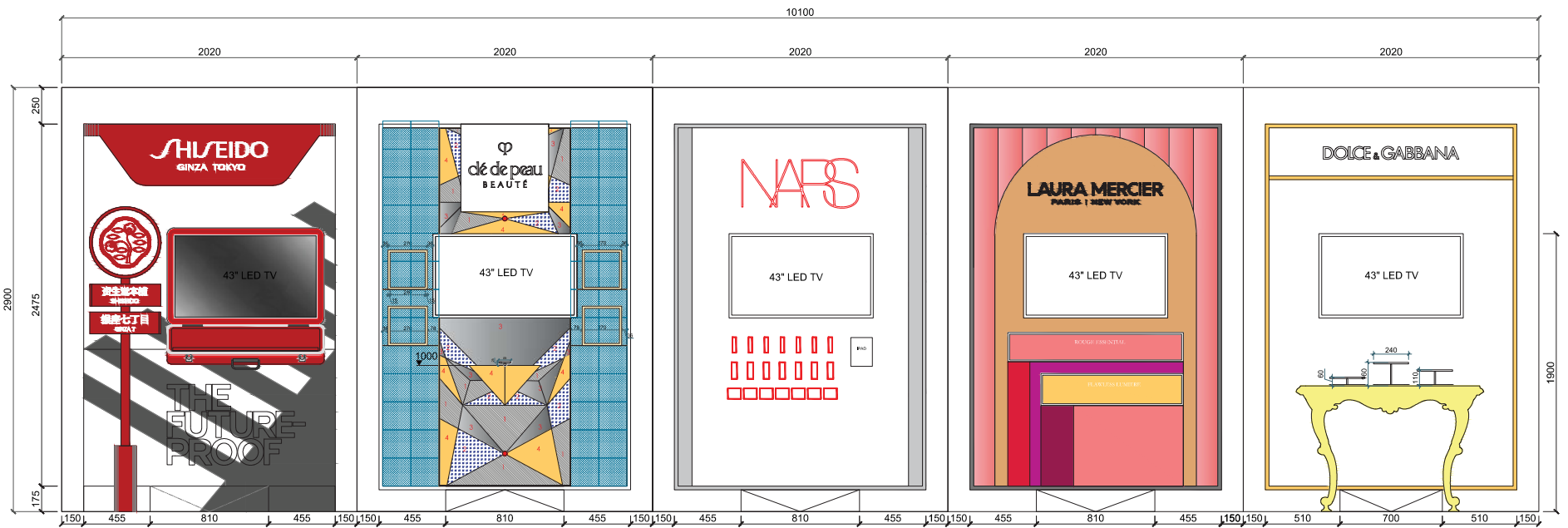

B FRONT VIEW
01 / SCALE 1:35

02 PERSPECTIVE VIEW

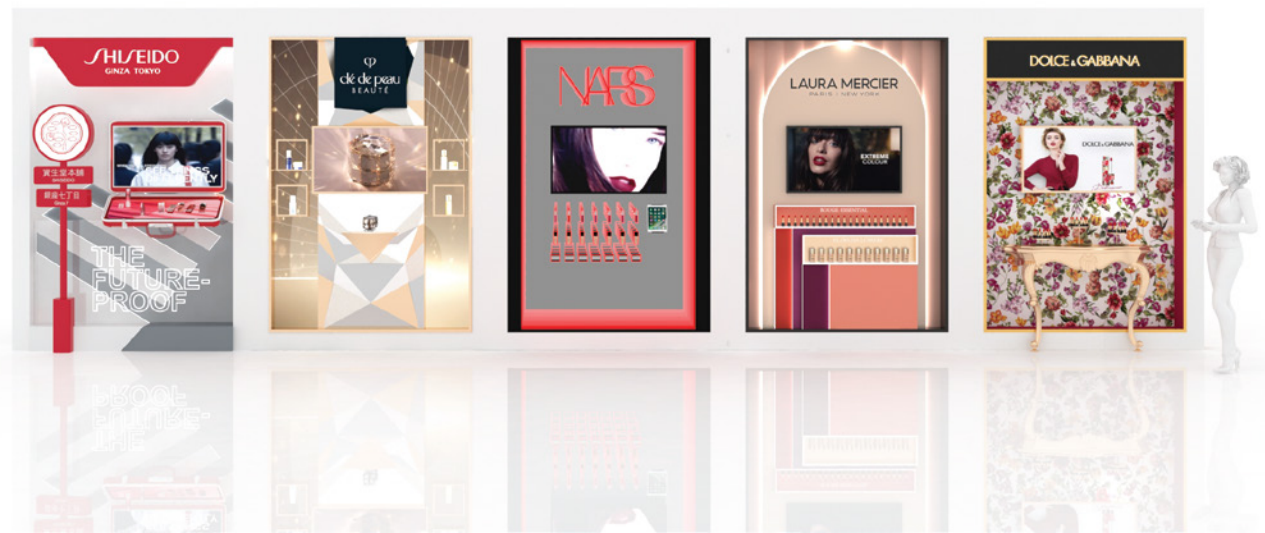





05 PERSPECTIVE VIEW





07 PERSPECTIVE VIEW



01 PERSPECTIVE VIEW

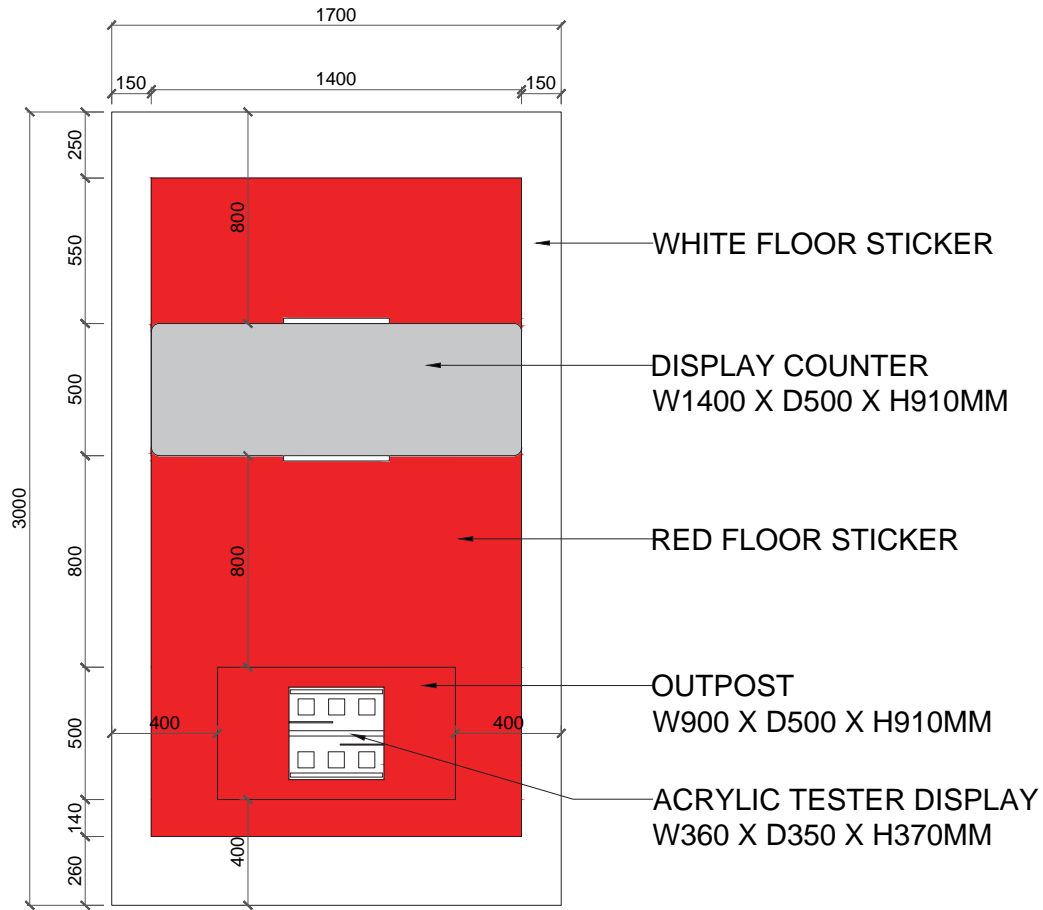

02 SUPER IMPOSED

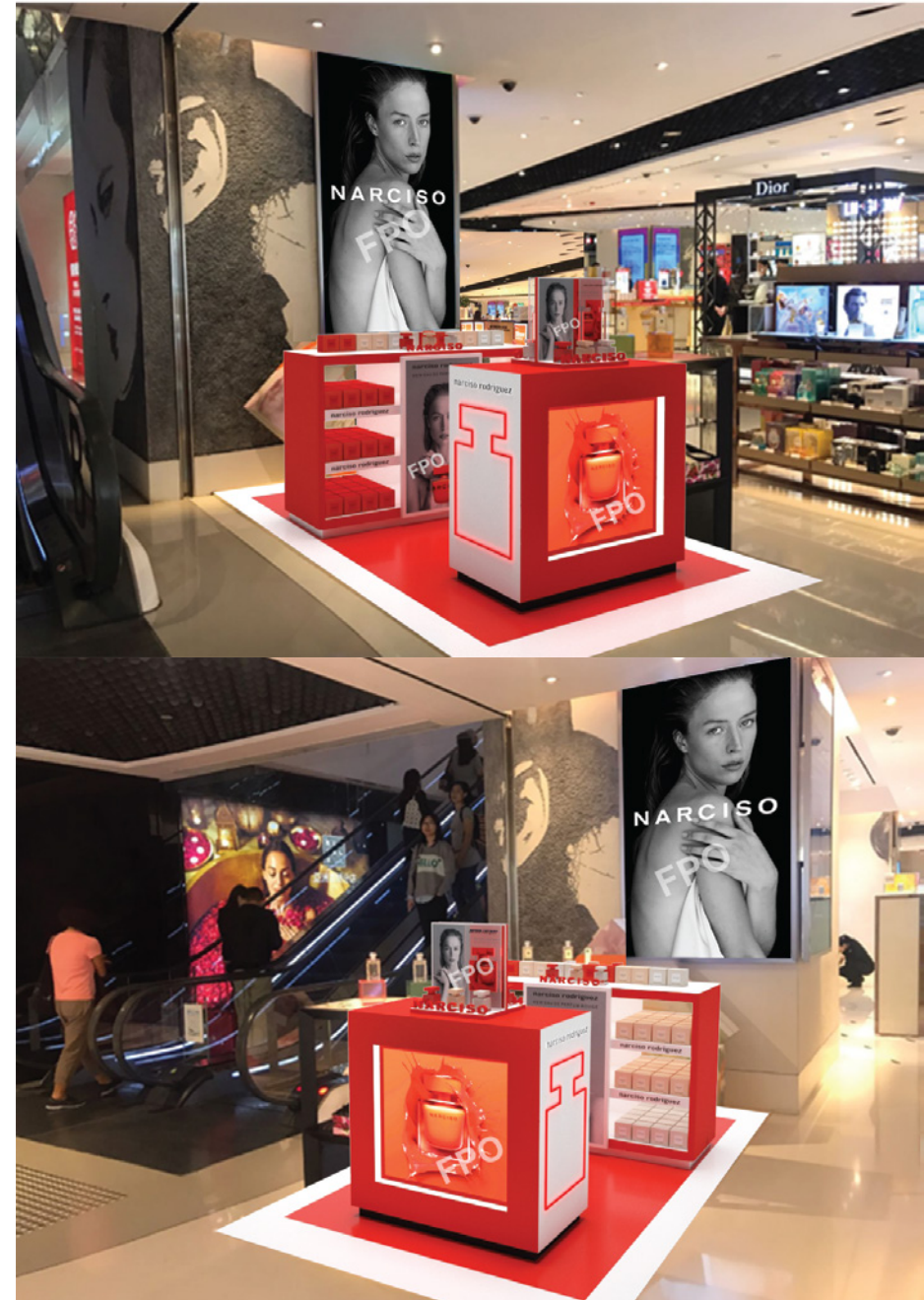

03 TECH DRAWING

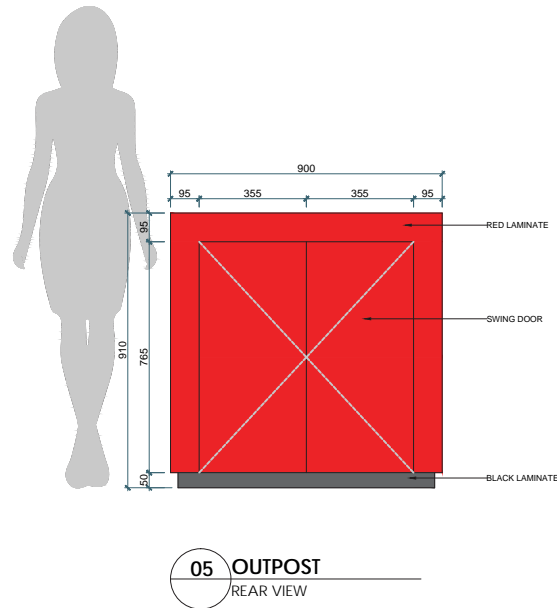
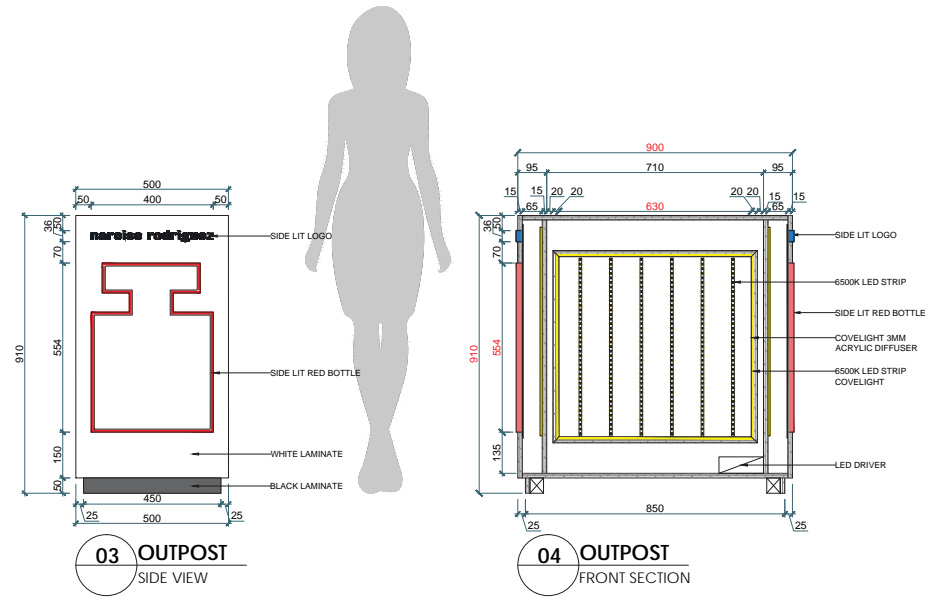
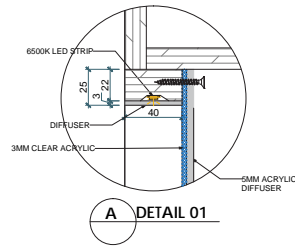
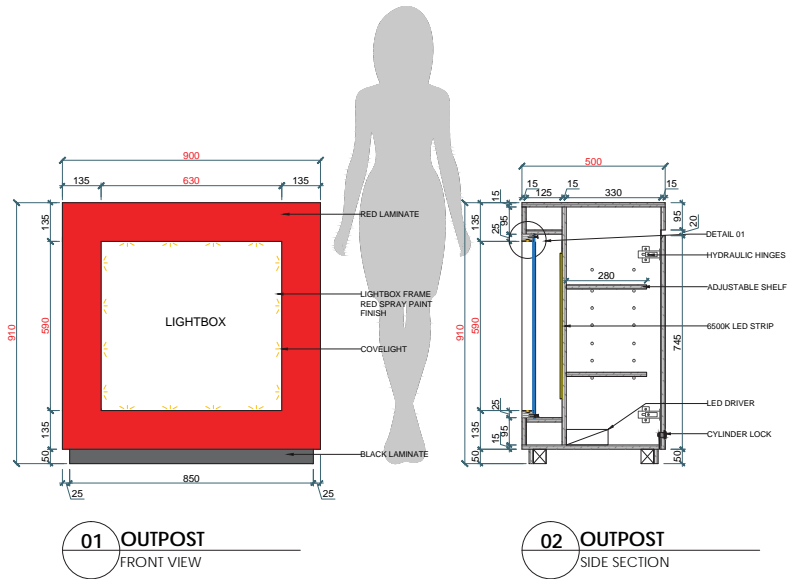

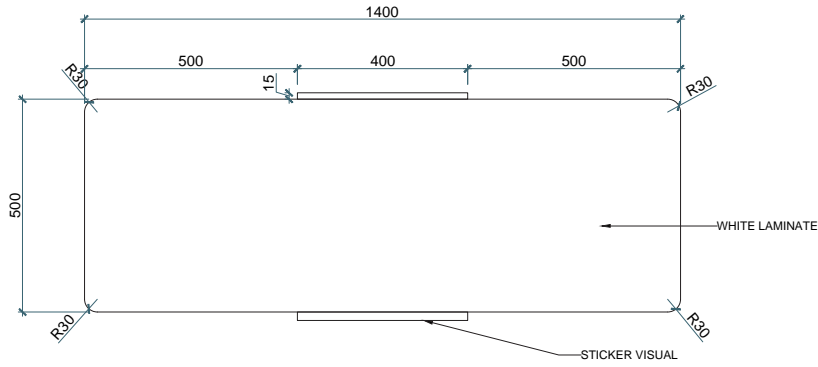

01 DISPLAY COUNTER
TOP VIEW



02 DISPLAY COUNTER
PERSPECTIVE VIEW

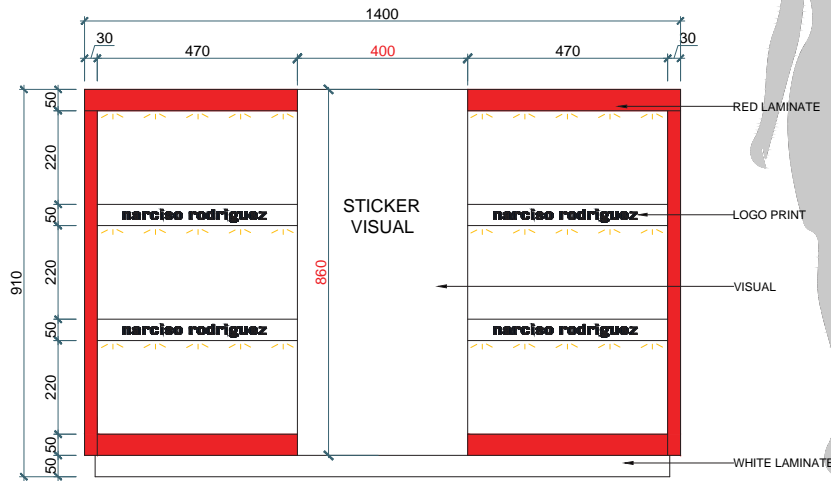

03 DISPLAY COUNTER
FRONT VIEW

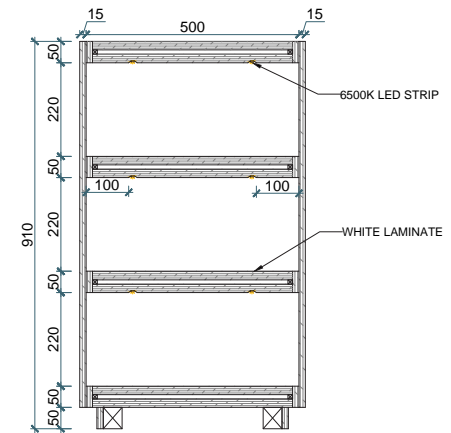
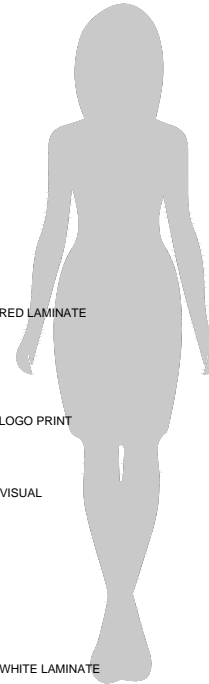

04 DISPLAY COUNTER
SIDE SECTION

05 TECH DRAWING

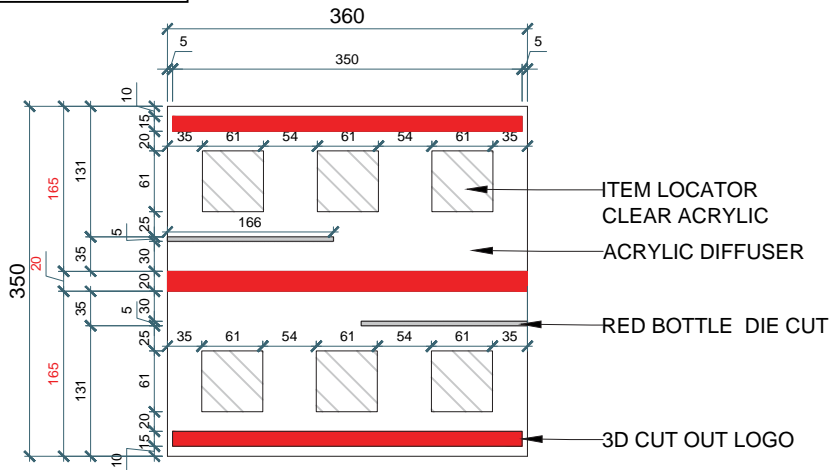

01 ACRYLIC TESTER DISPLAY
TOP VIEW



02 ACRYLIC TESTER DISPLAY
PERSPECTIVE VIEW

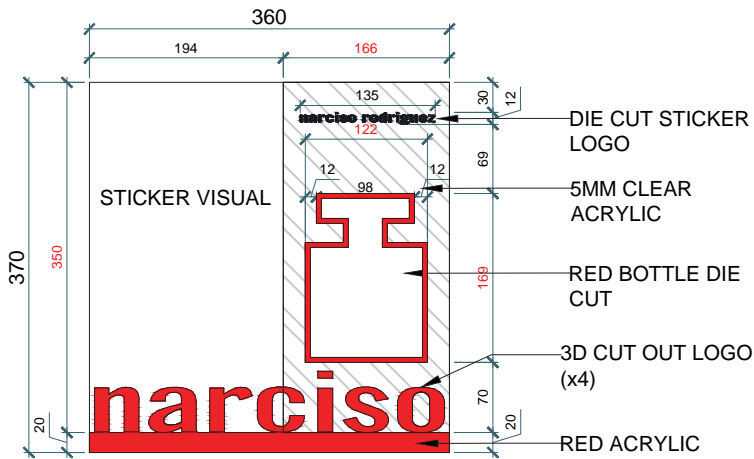

03 ACRYLIC TESTER DISPLAY
FRONT VIEW

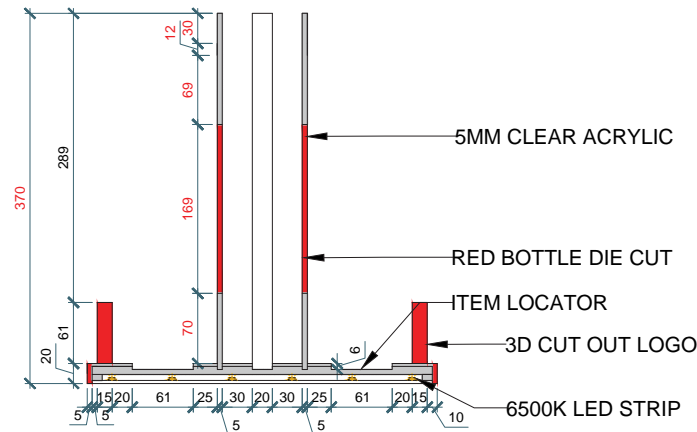

04 ACRYLIC TESTER DISPLAY
SIDE SECTION



Location:
SINGAPORE T1 SPP23

01 PERSPECTIVE VIEW

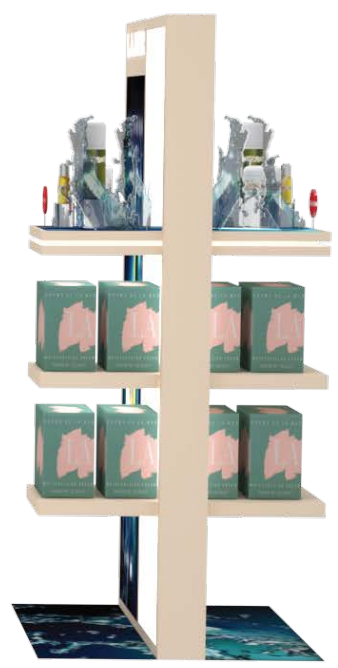

02 ACTUAL PHOTOS



01 PERSPECTIVE VIEW



02 ACTUAL PHOTOS



01 PERSPECTIVE VIEW



02 ACTUAL PHOTOS

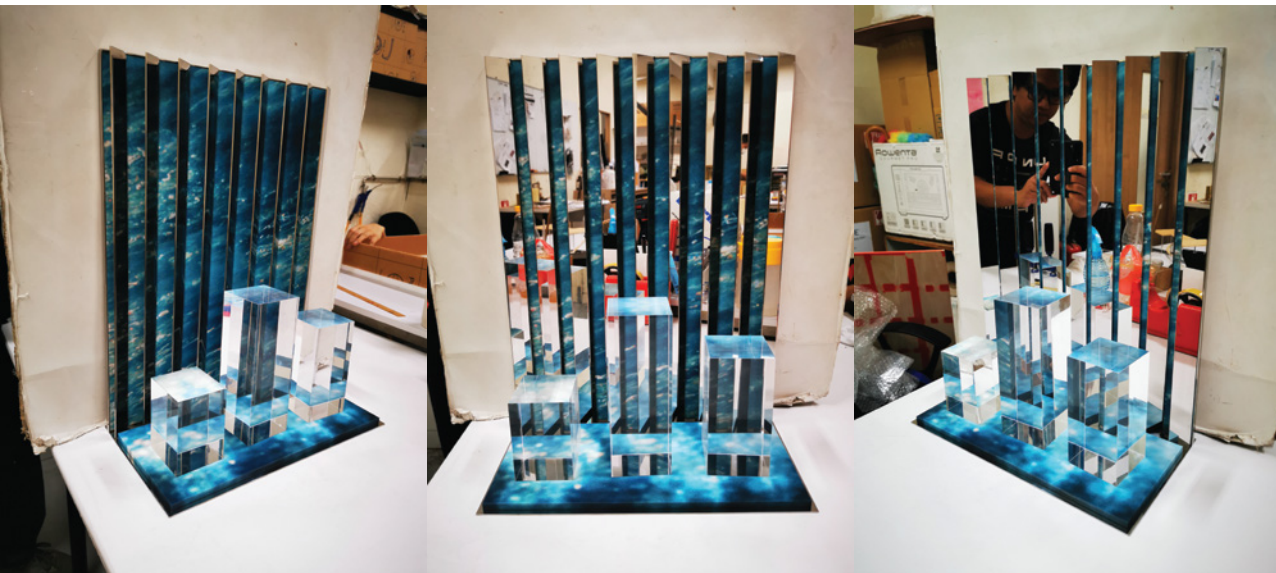

01 PERSPECTIVE VIEW



02 SUPER IMPOSED



03 ACTUAL PHOTO



Location:
DT1 HPP2 THAILAND

01 PLAN VIEW

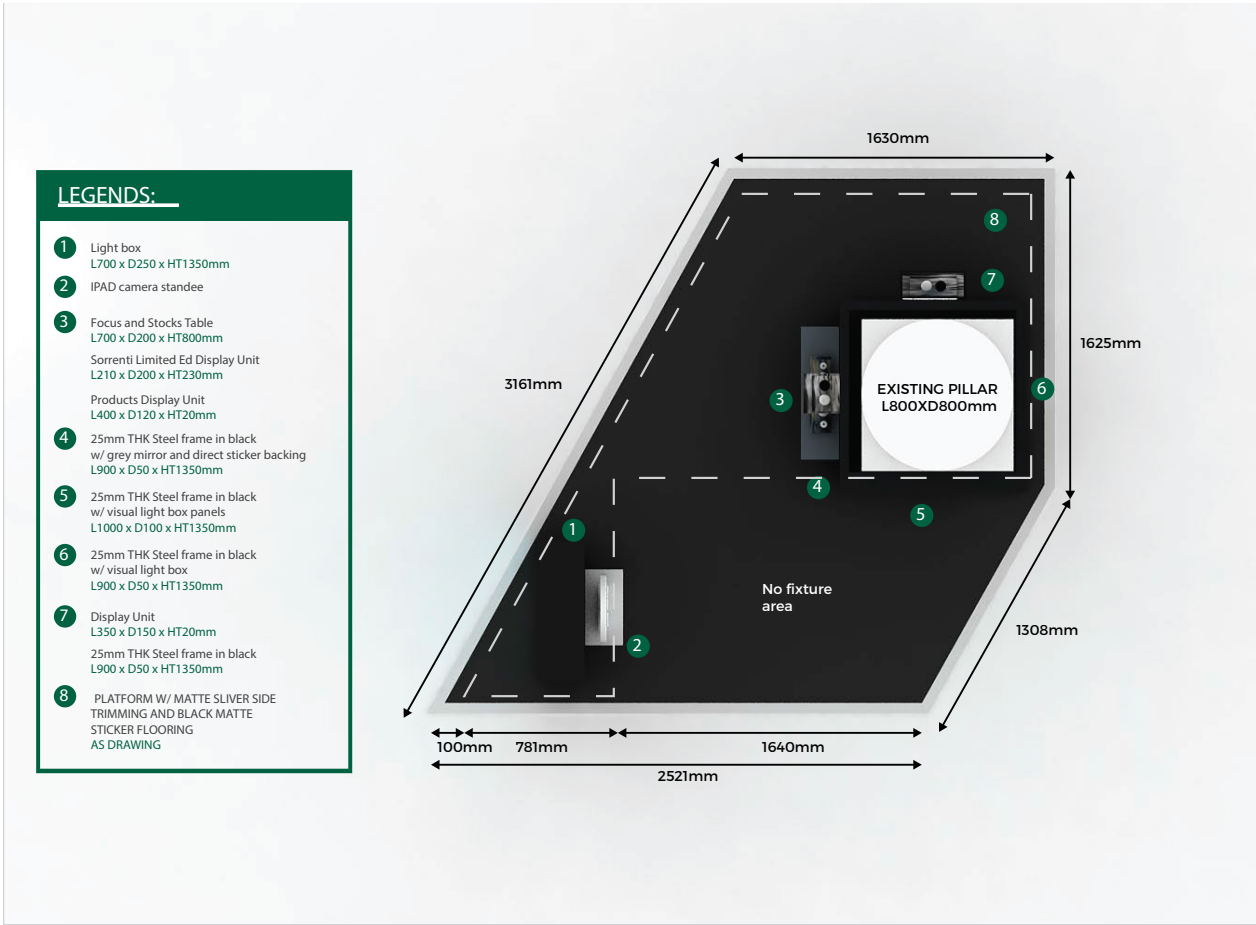

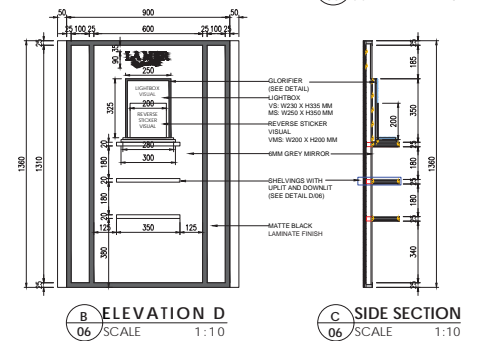
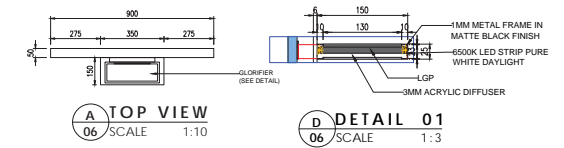
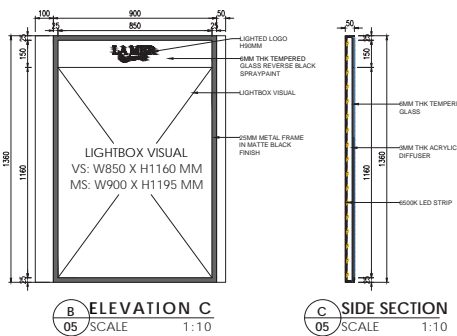
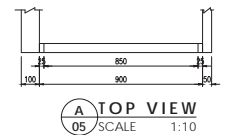
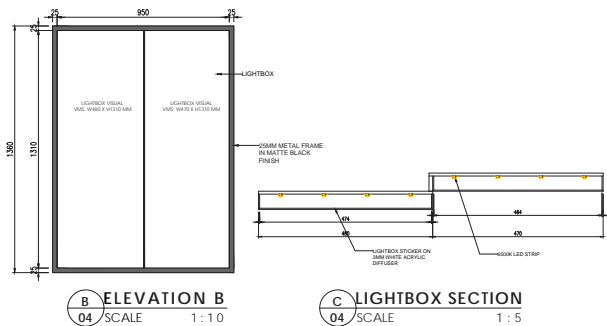
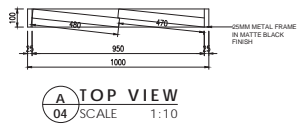
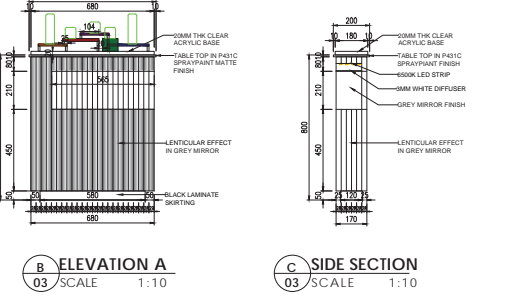
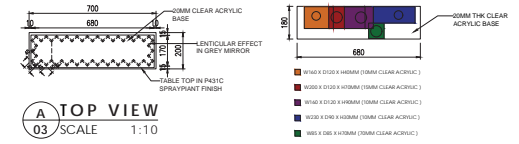
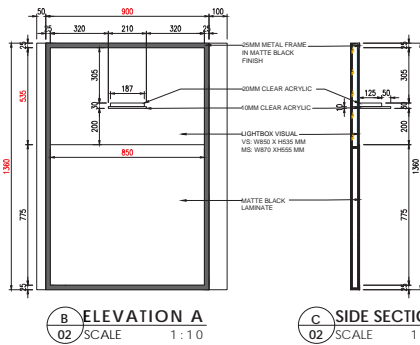
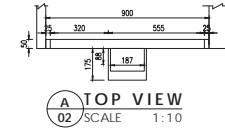
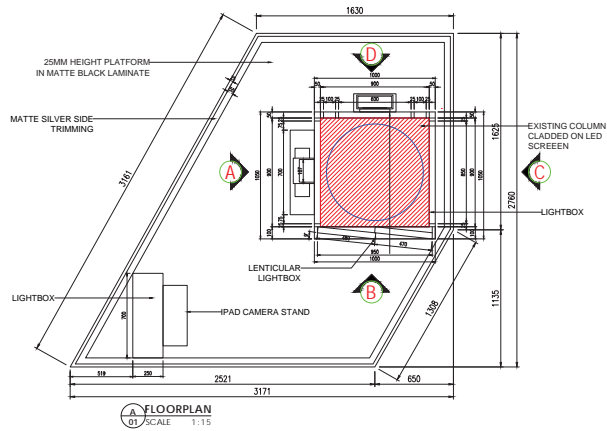



01 PERSPECTIVE VIEW





COMMERCIAL DESIGN

2017 - 2018

01 LAY OUT PLAN

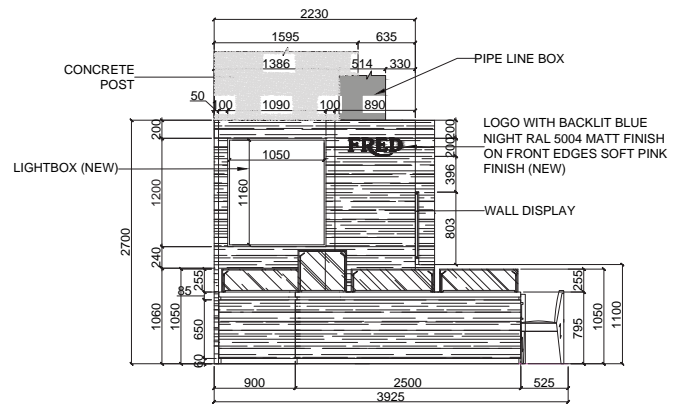
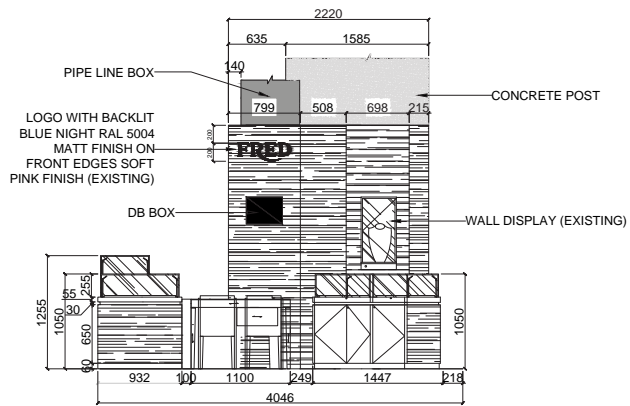
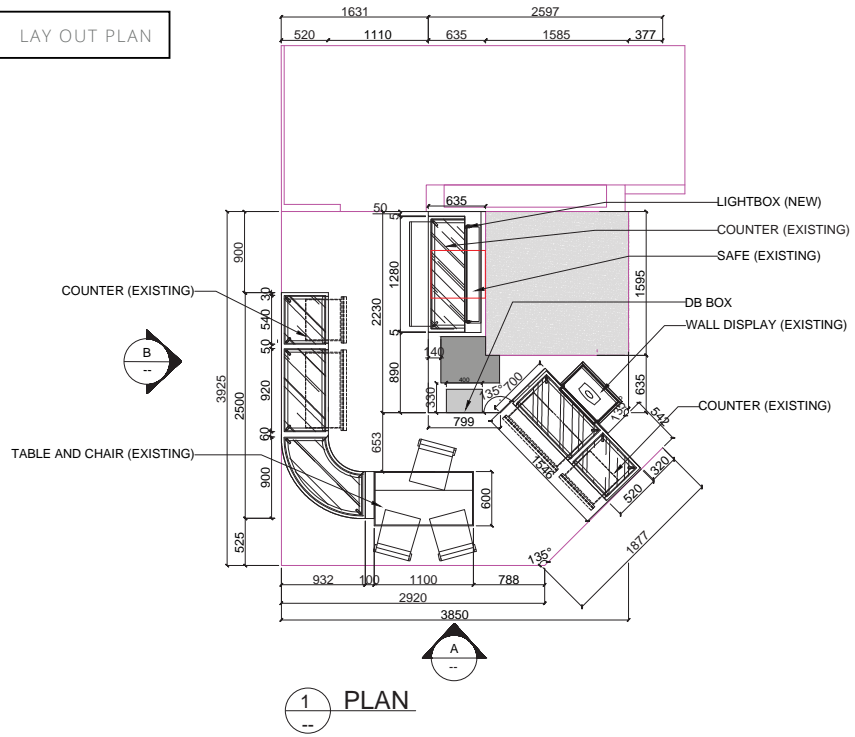



01 LAY OUT PLAN

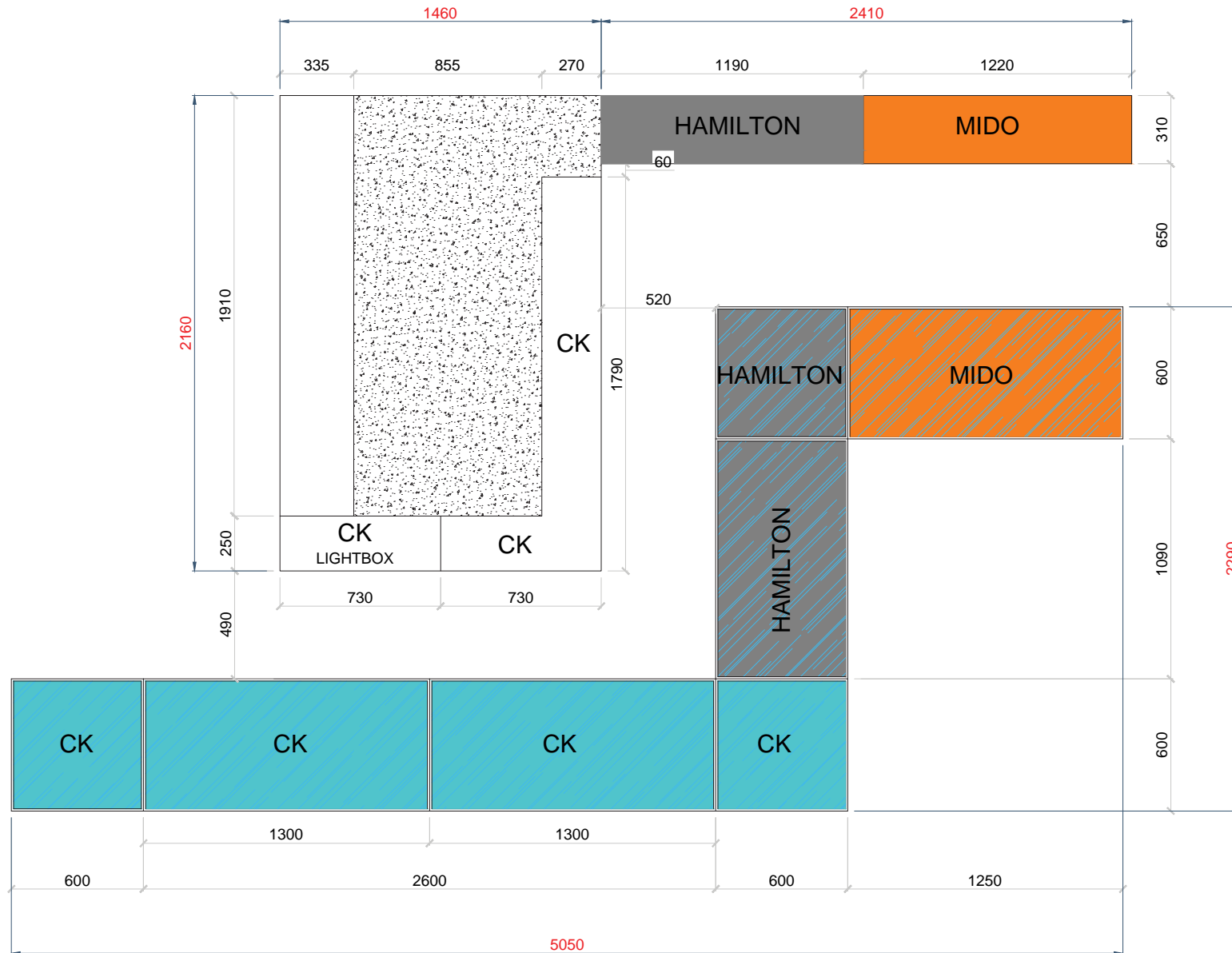



Location:
MUSTAFA CENTRE

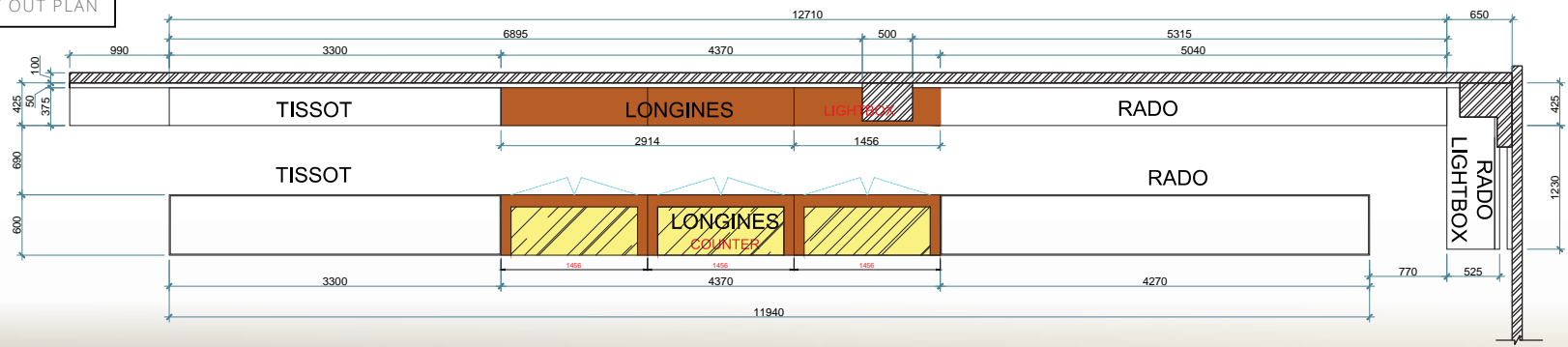

Location:
SWISS WATCH GALLERY - RESORTS WORLD SENTOSA

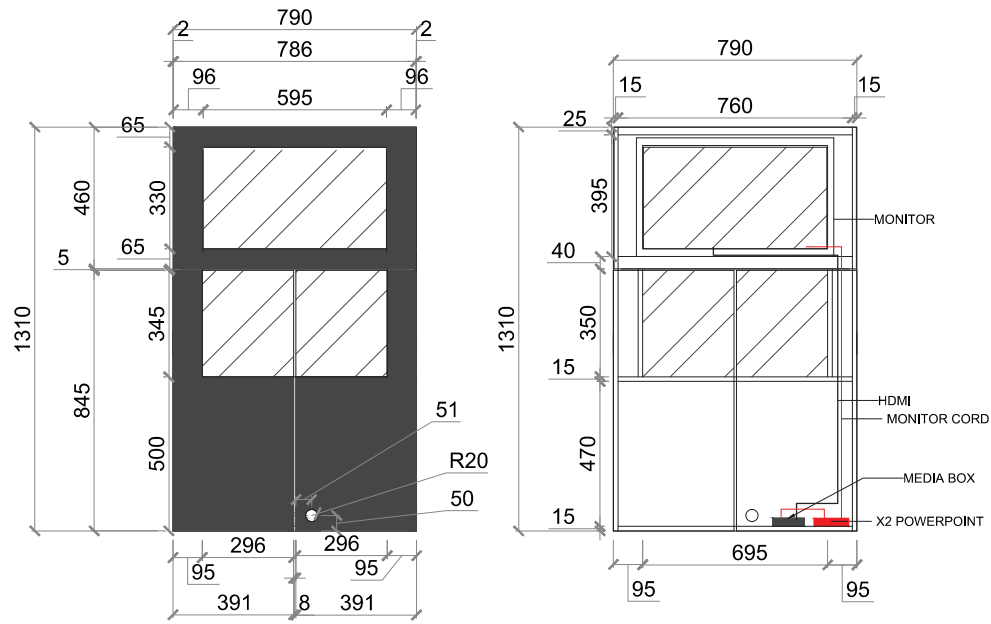

01 LAY OUT PLAN

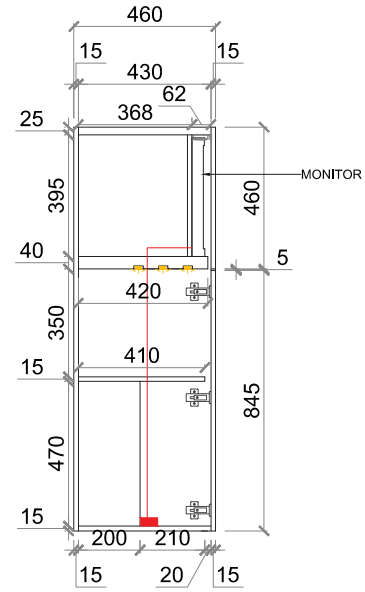

02 PERSPECTIVE VIEW





01 PERSPECTIVE VIEW

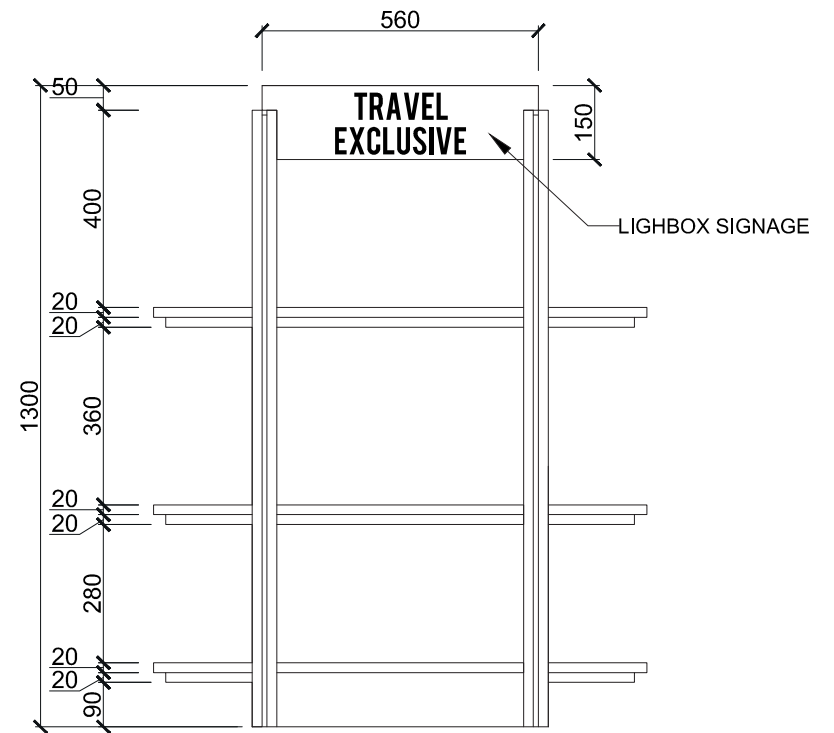
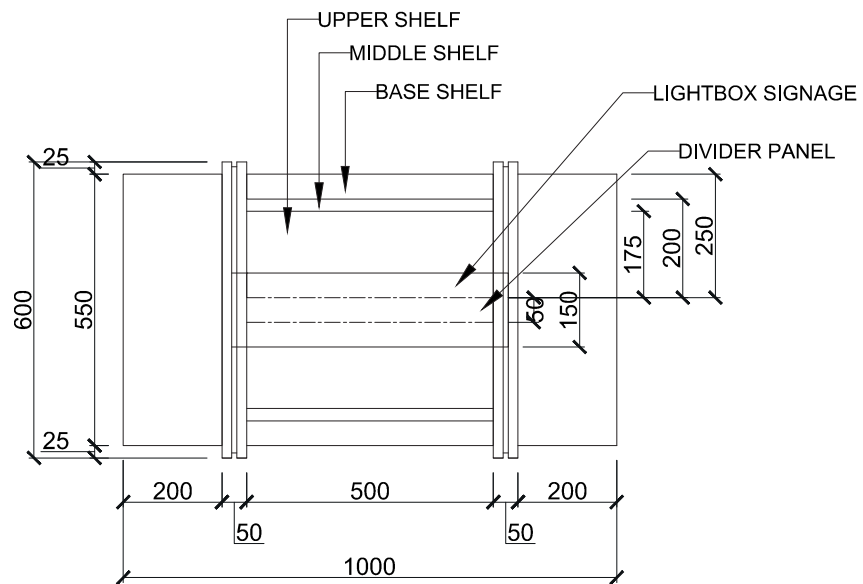

02 LAY OUT PLAN

03 ACTUAL PHOTO



Location:
TAKASHIMAYA NGEE ANN CITY

01 LAY OUT PLAN

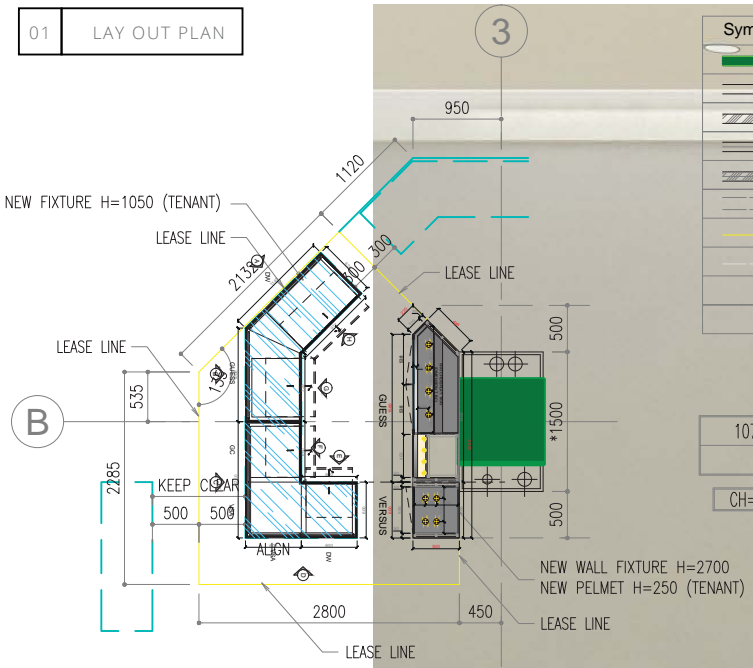

| Symbol | Legend |
|--------|---------------------------|
| | Structural Wall |
| | No Full-height Wall |
| | Full-height Wall |
| | No Full-height Wall (New) |
| | Full-height Wall (New) |
| | New Dec-Beam / Light Box |
| | Lease Line |
| | Existing Lease Line |

| | |
|---------|-----------------------|
| 107-5 | 8.98 M ² |
| | 96.66 FT ² |
| CH=4000 | FL ±0 |

B

3

02 PERSPECTIVE VIEW

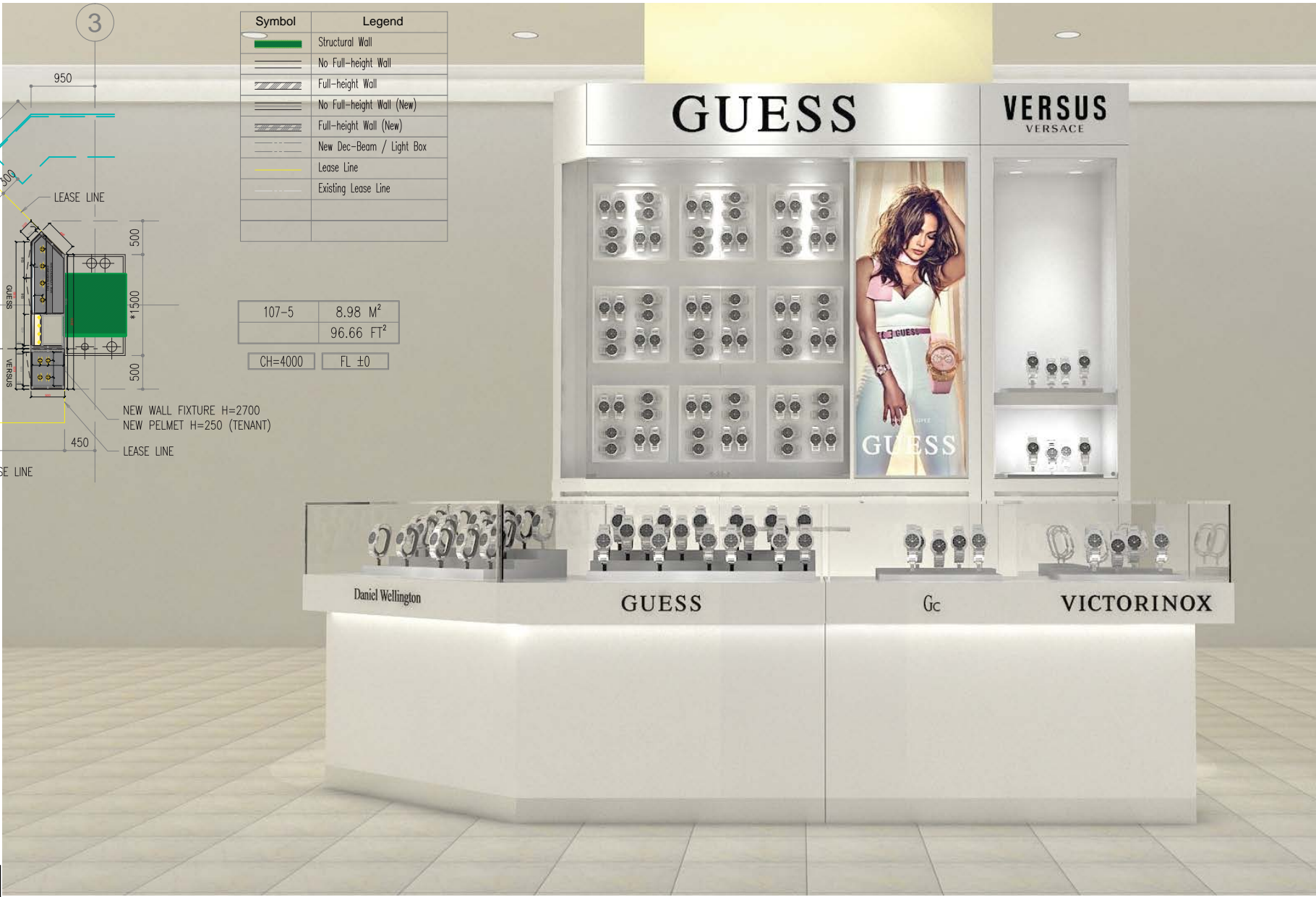

03 ELEVATION

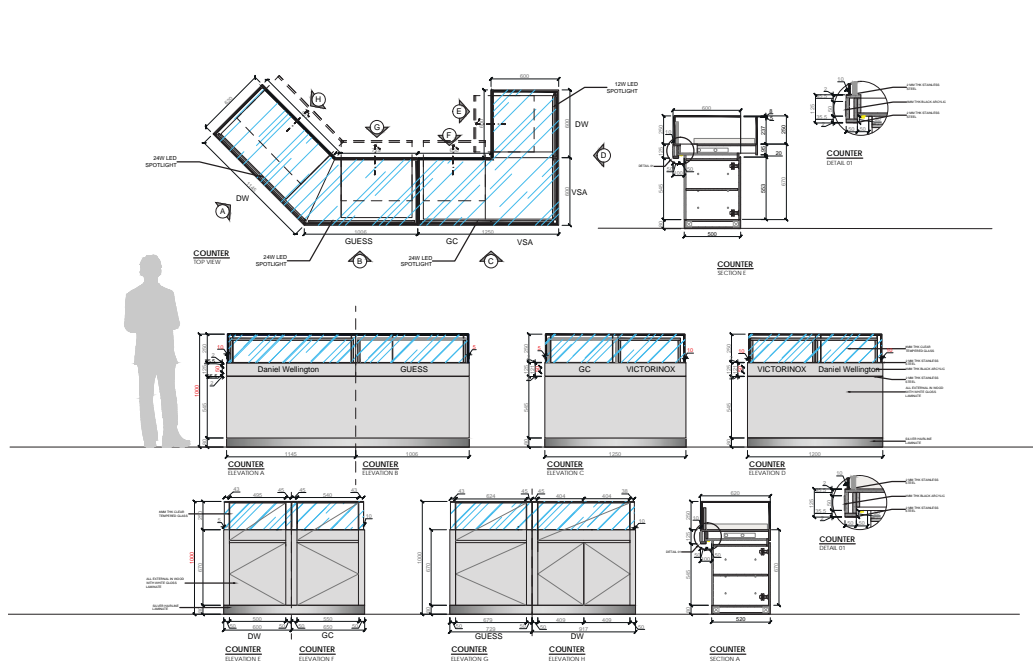
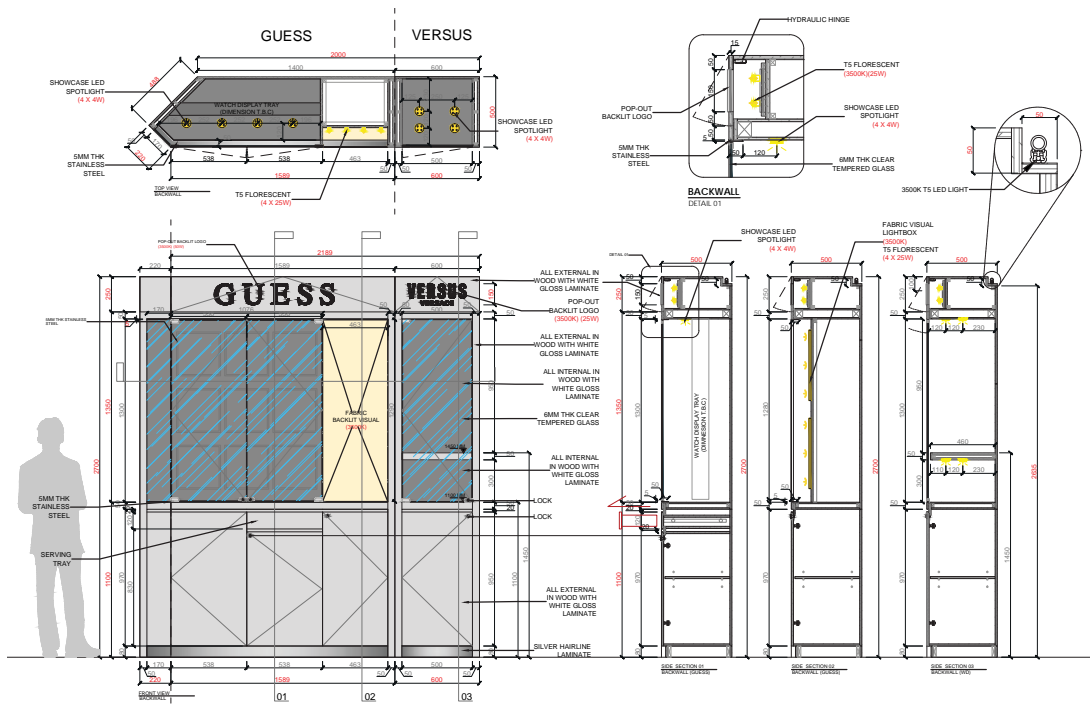

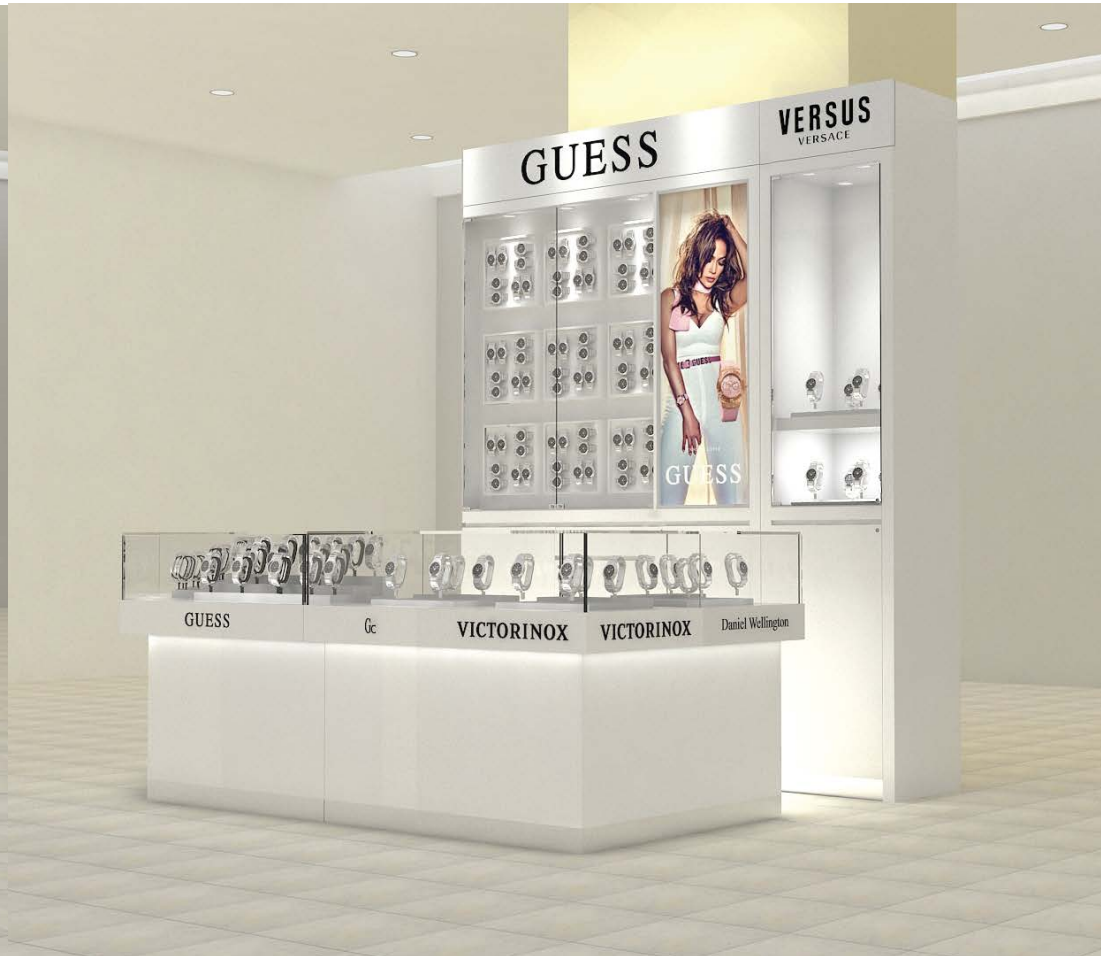

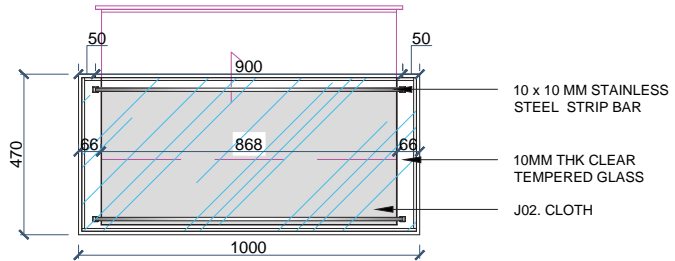

COUNTER
TOP VIEW



COUNTER
PERSPECTIVE VIEW

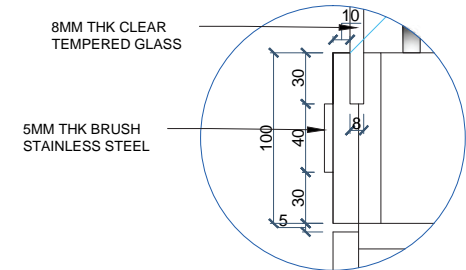

COUNTER DETAIL 01
SCALE: 1:5

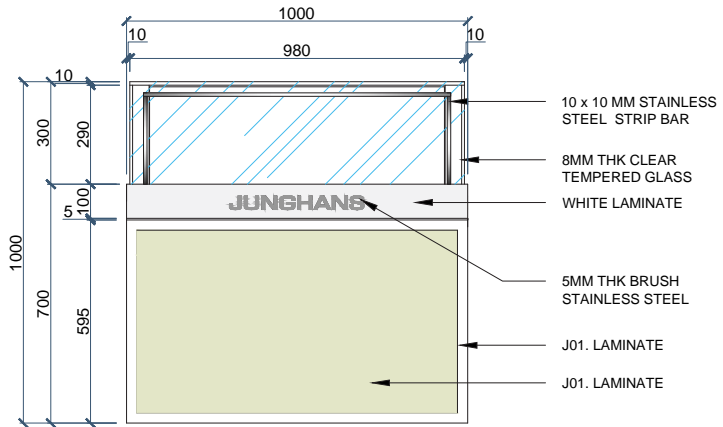

COUNTER
FRONT VIEW

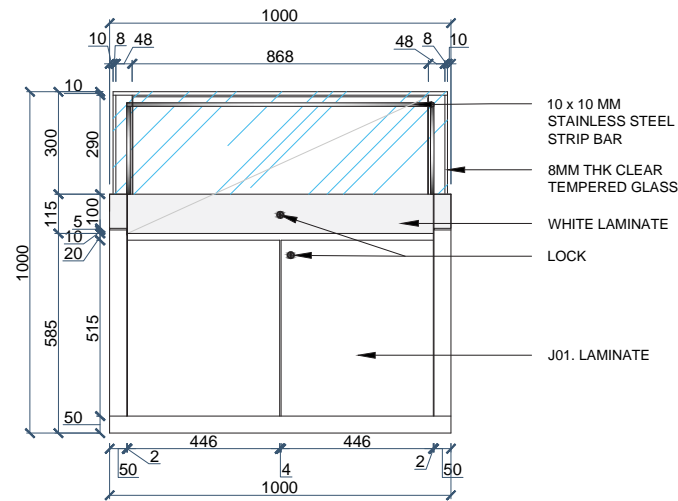

COUNTER
REAR VIEW

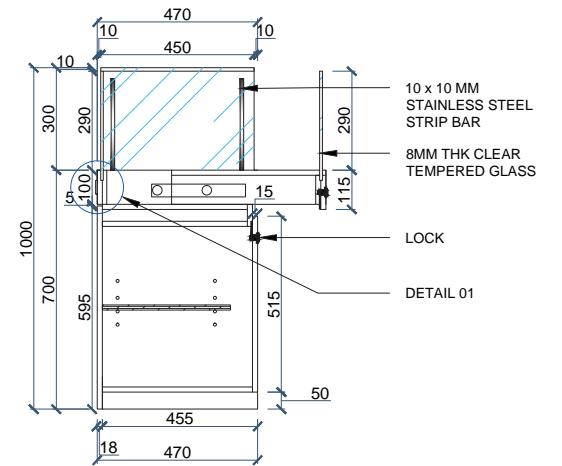

COUNTER
SIDE SECTION

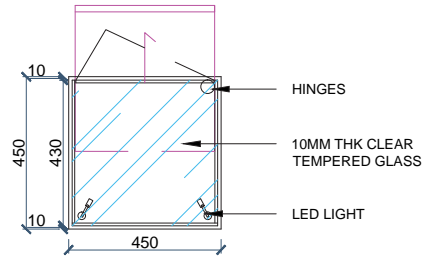

COUNTER
SIDE SECTION

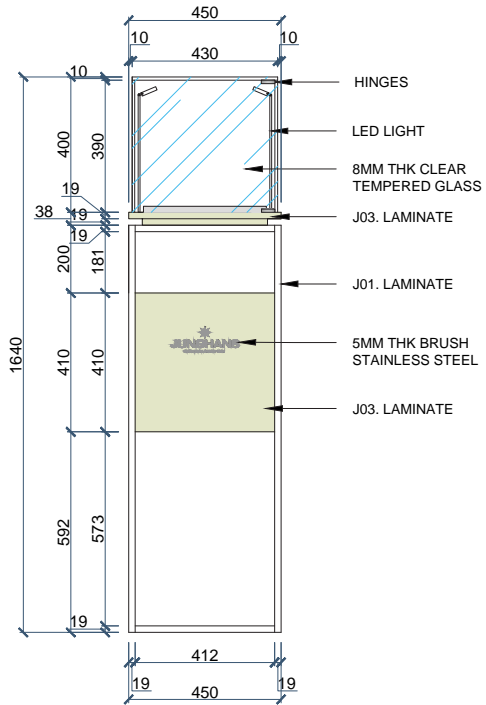

TOWER
FRONT VIEW

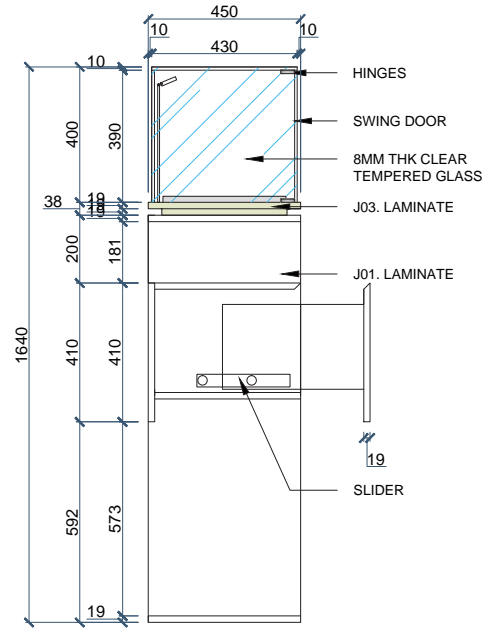

TOWER
SIDE SECTION

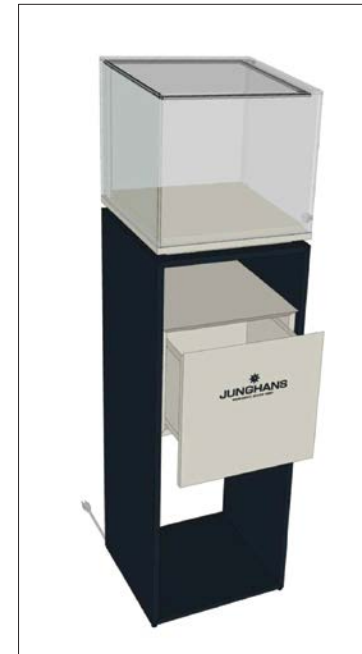

TOWER
PERSPECTIVE VIEW



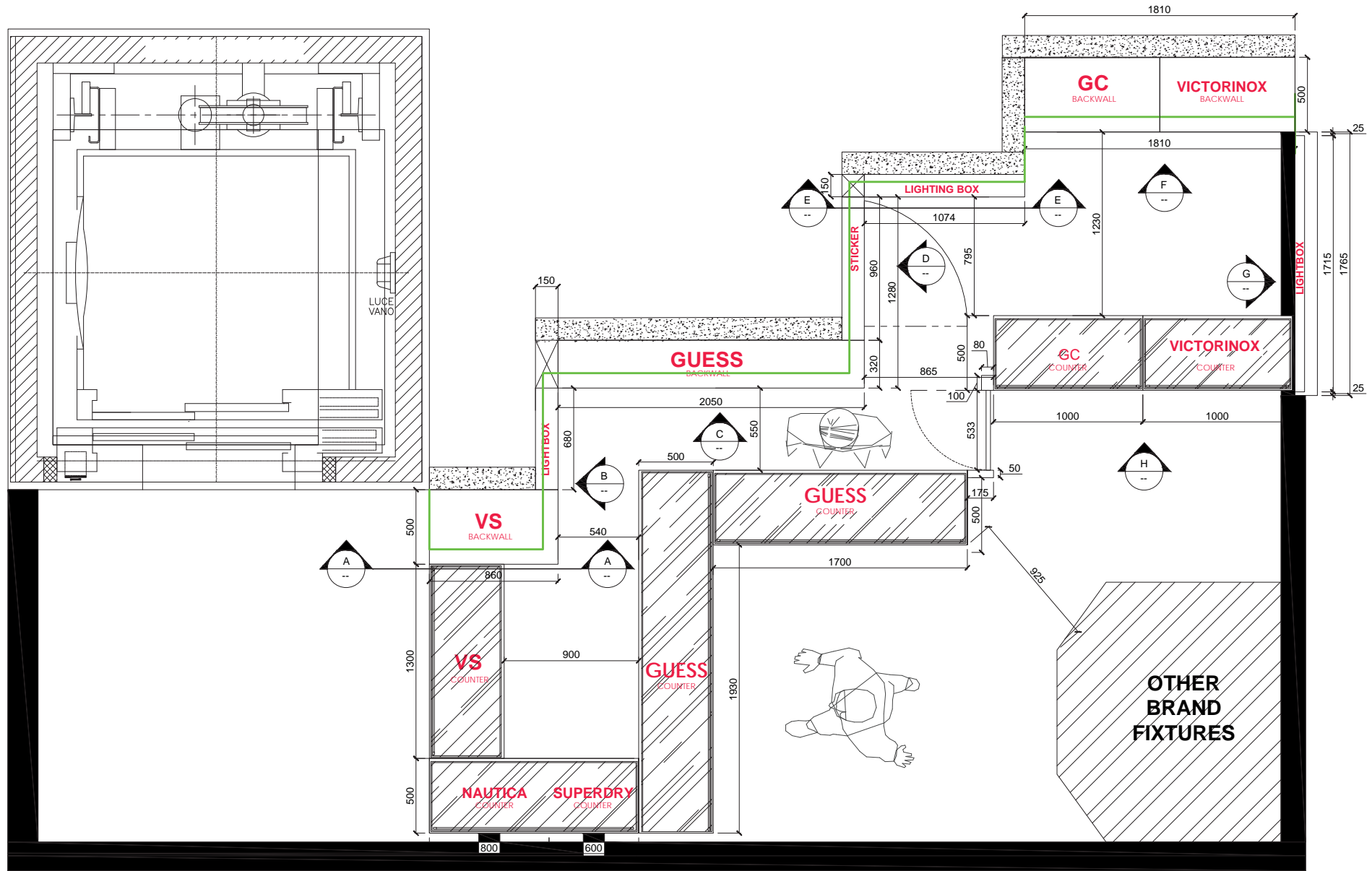

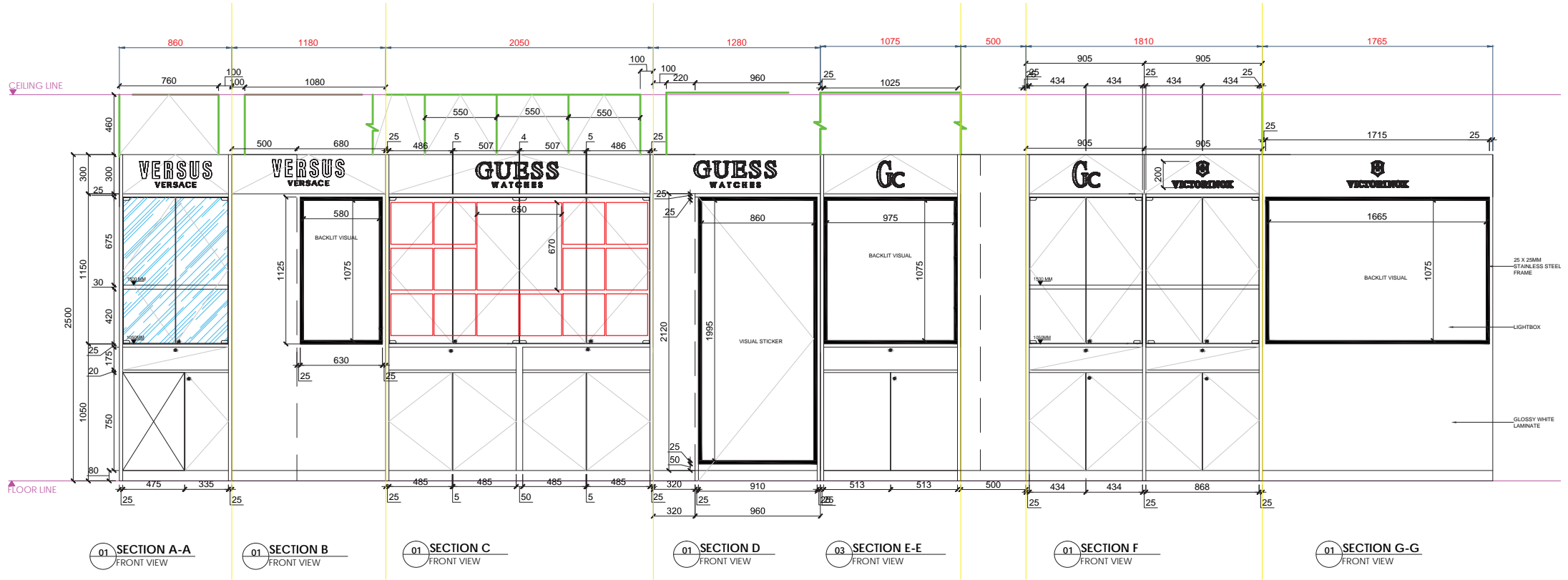

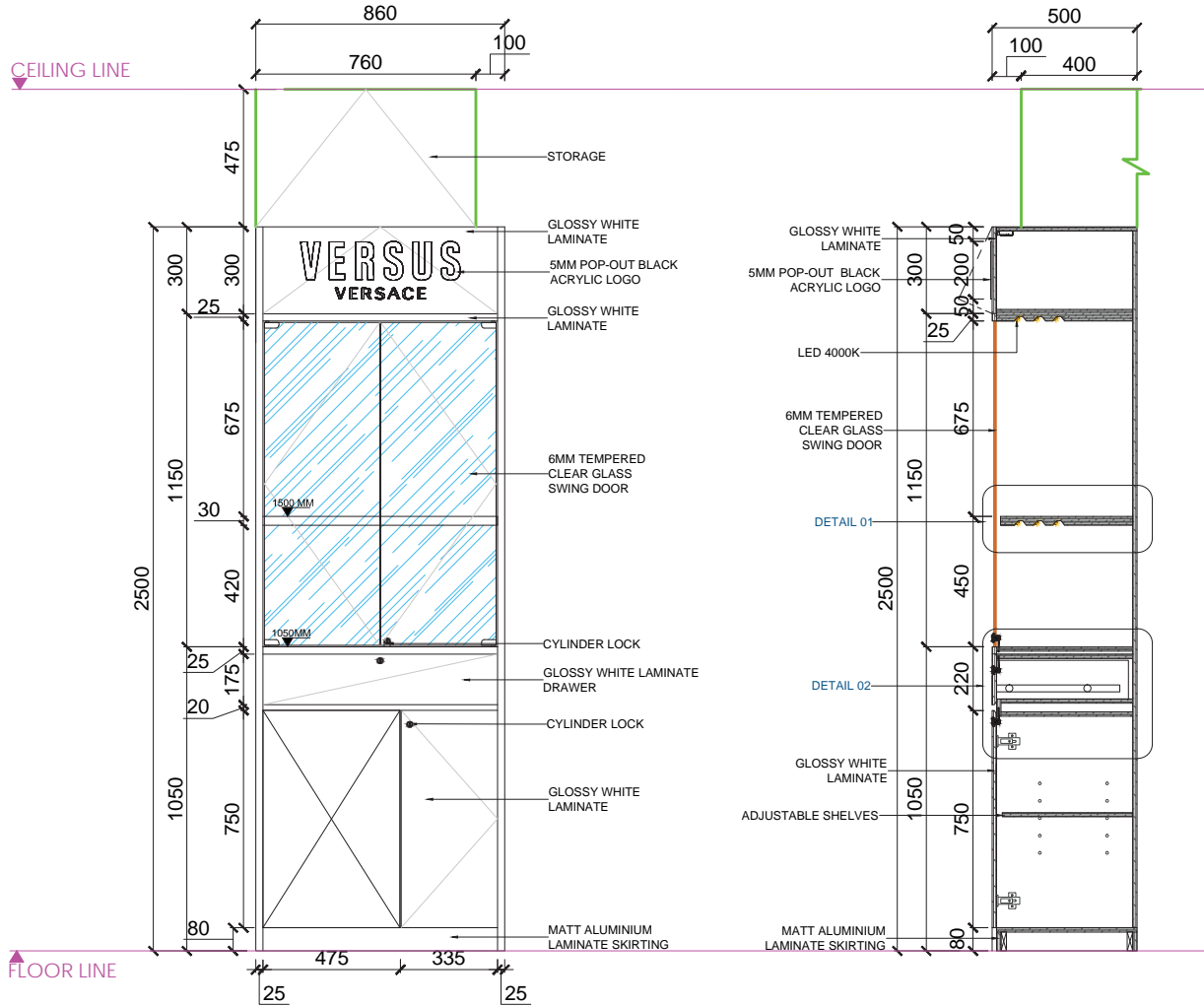

01 SECTION A-A
FRONT VIEW

02 SECTION A-A
SIDE VIEW

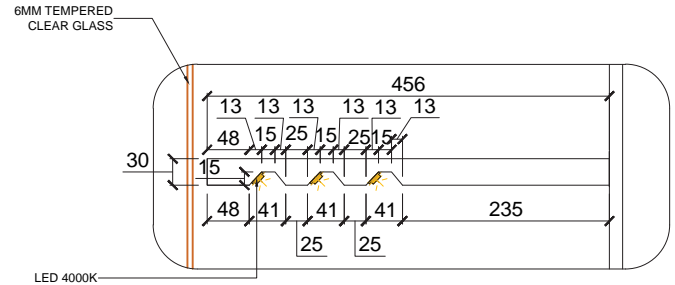

03 SECTION A-A DETAIL 1
SCALE 1:3

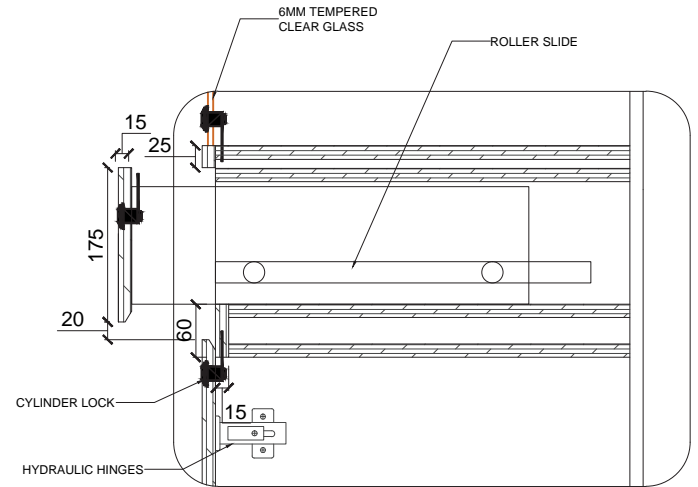

04 SECTION A-A DETAIL 2
SCALE 1:3

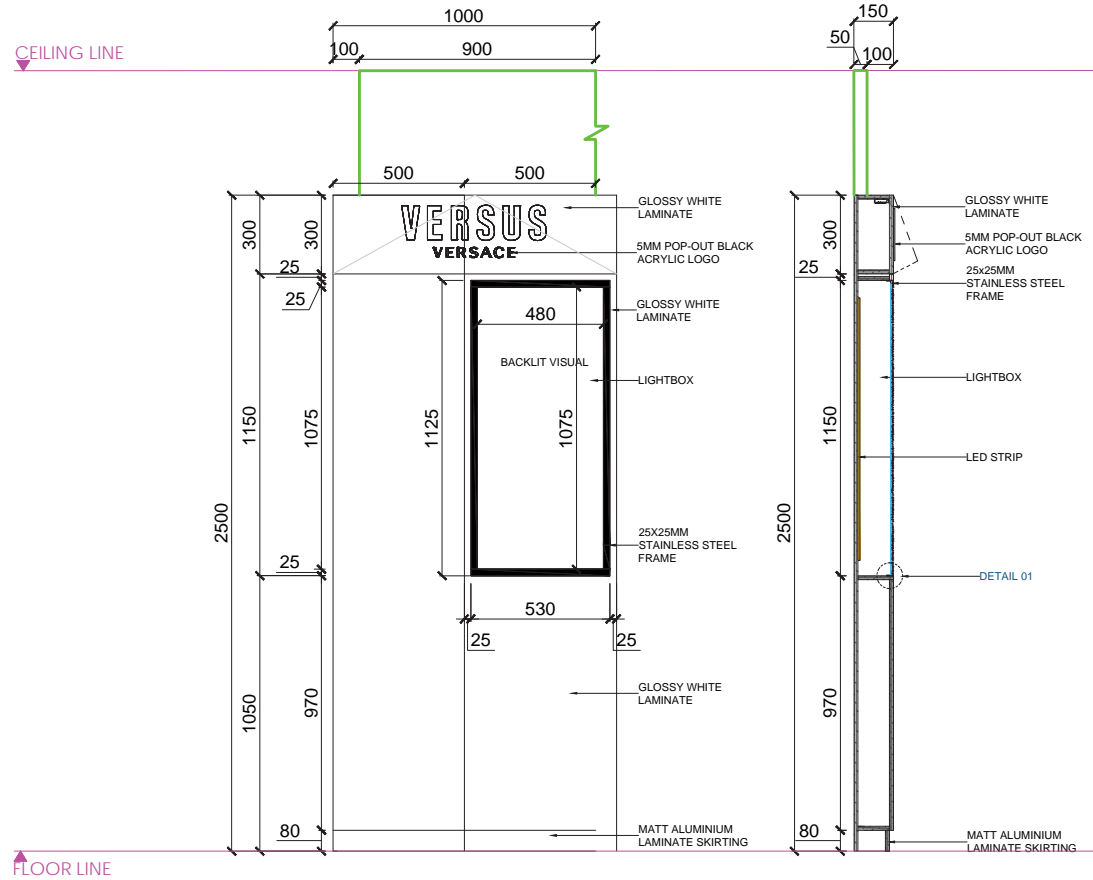

01 SECTION B
FRONT VIEW

02 SECTION B
SIDE VIEW

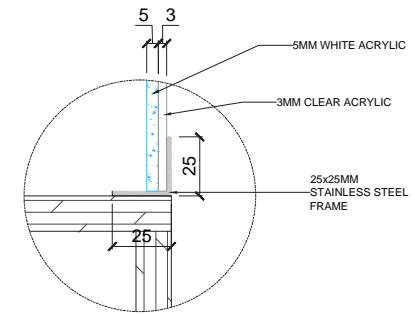

03 SECTION B DETAIL 1
SCALE 1:9

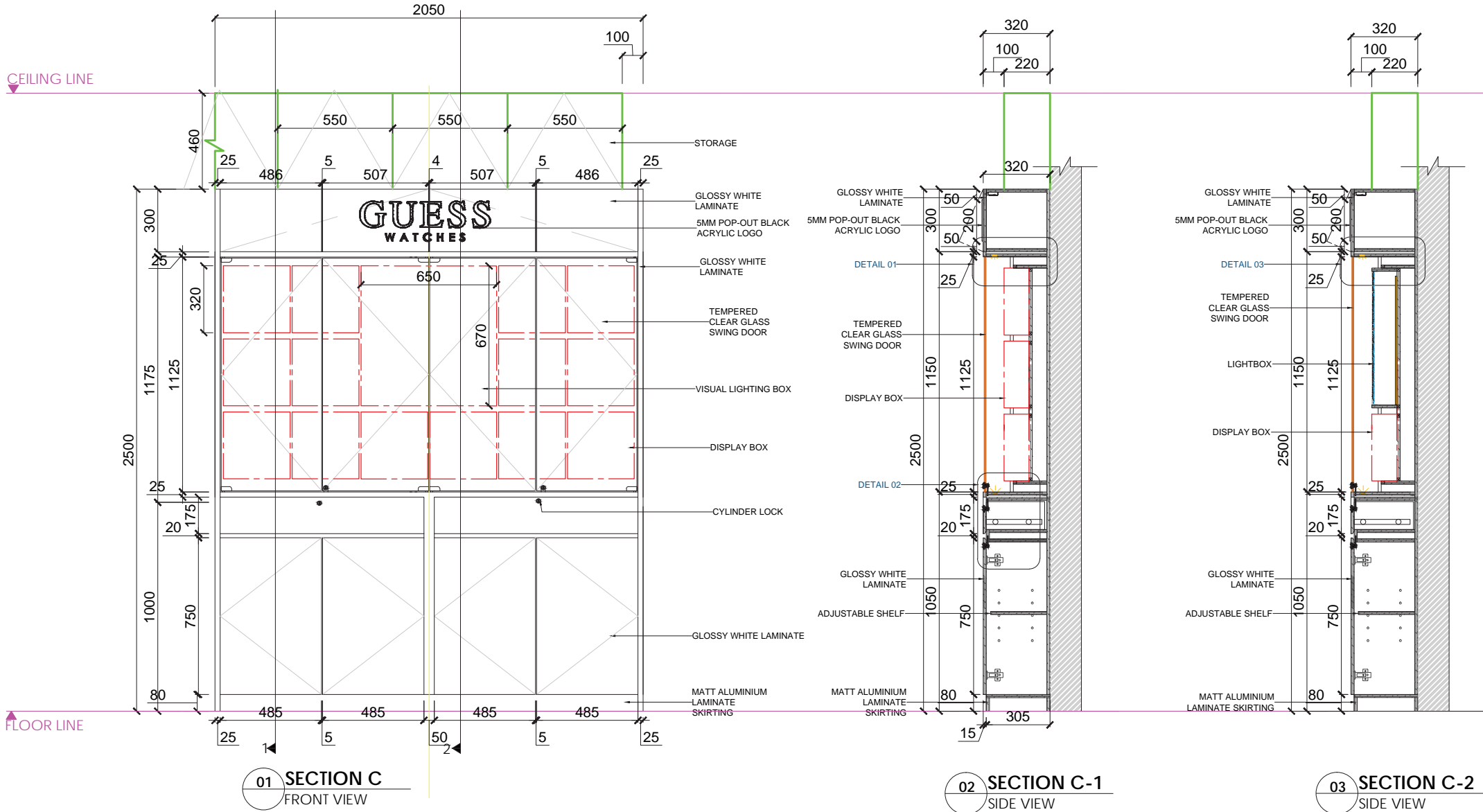

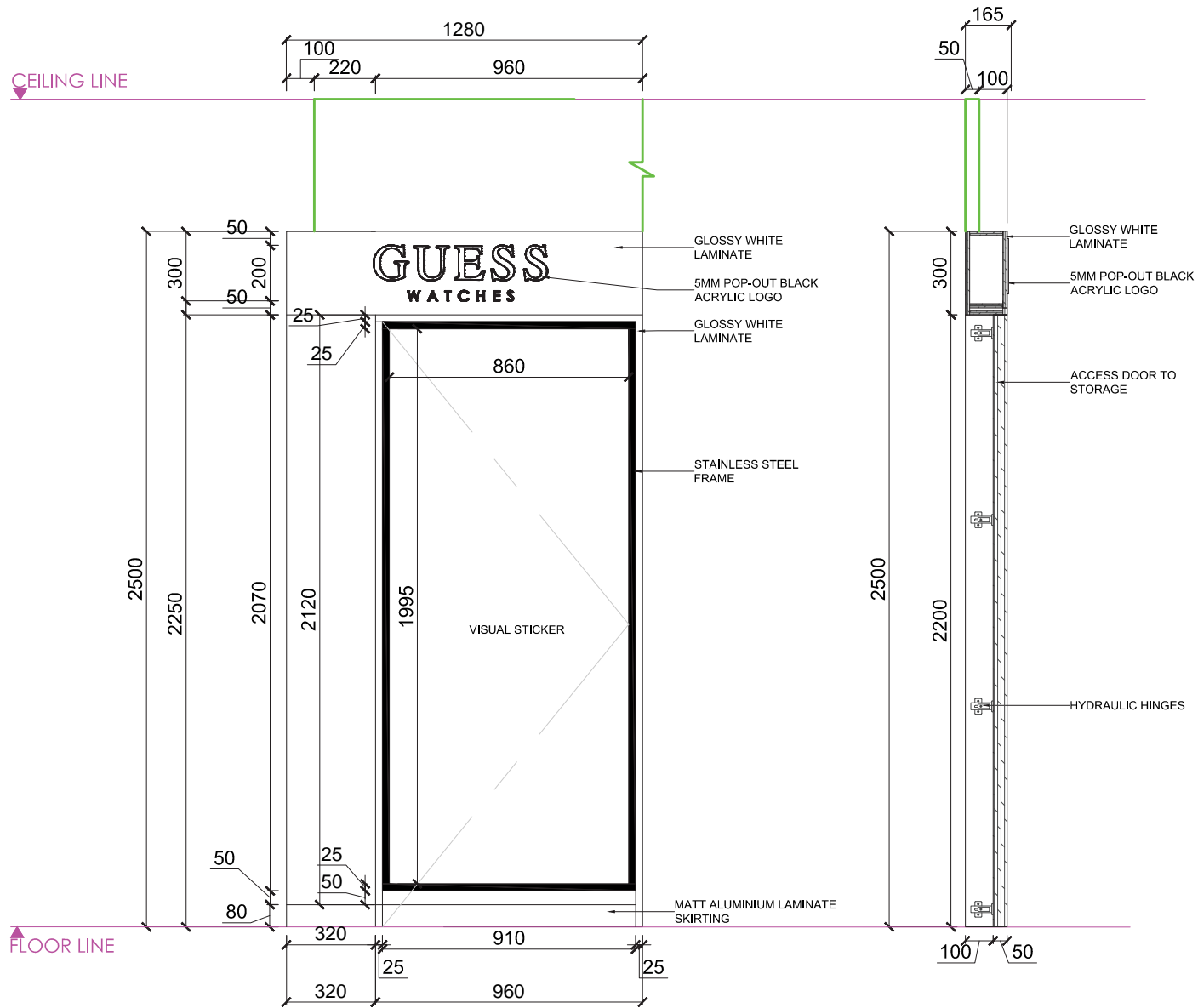

01 SECTION D
FRONT VIEW

02 SECTION D
SIDE VIEW

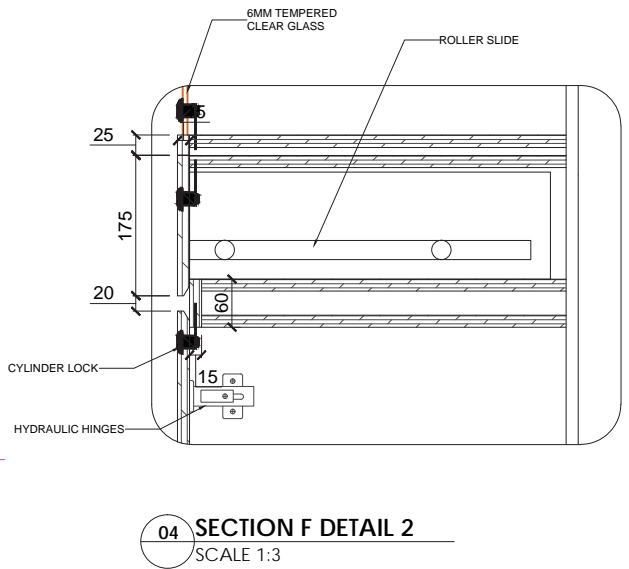
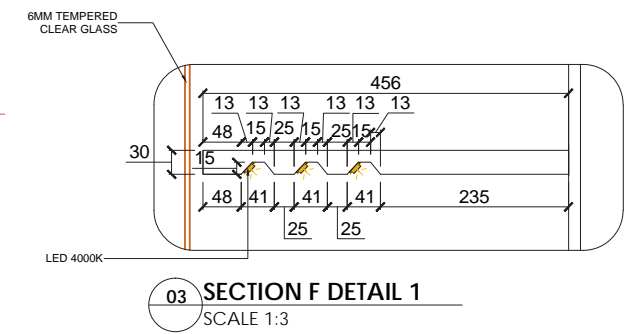
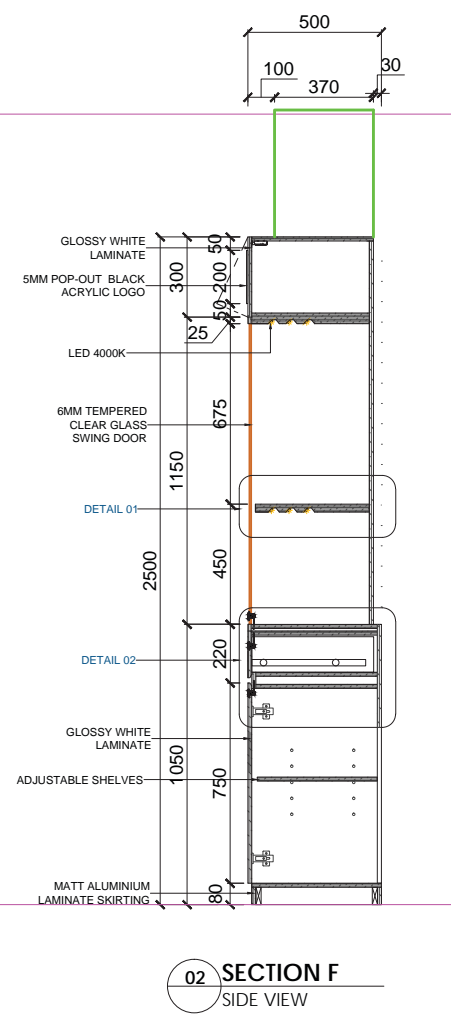
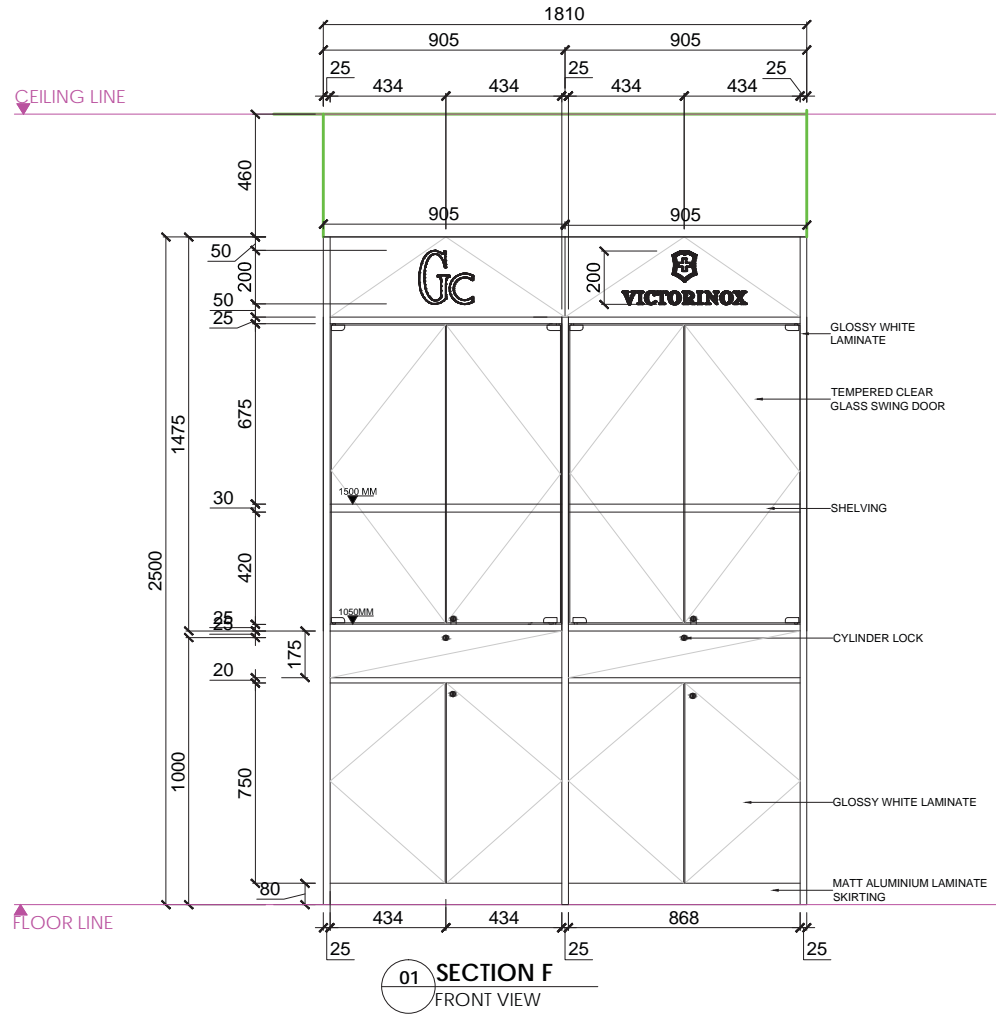

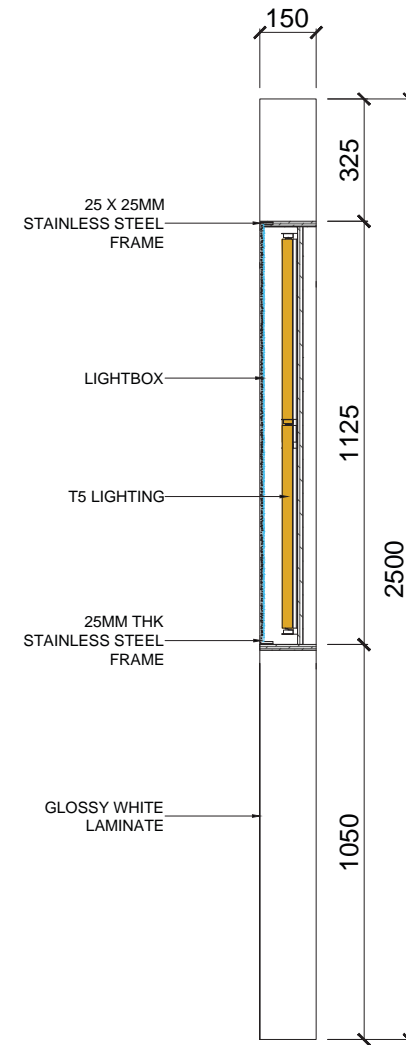
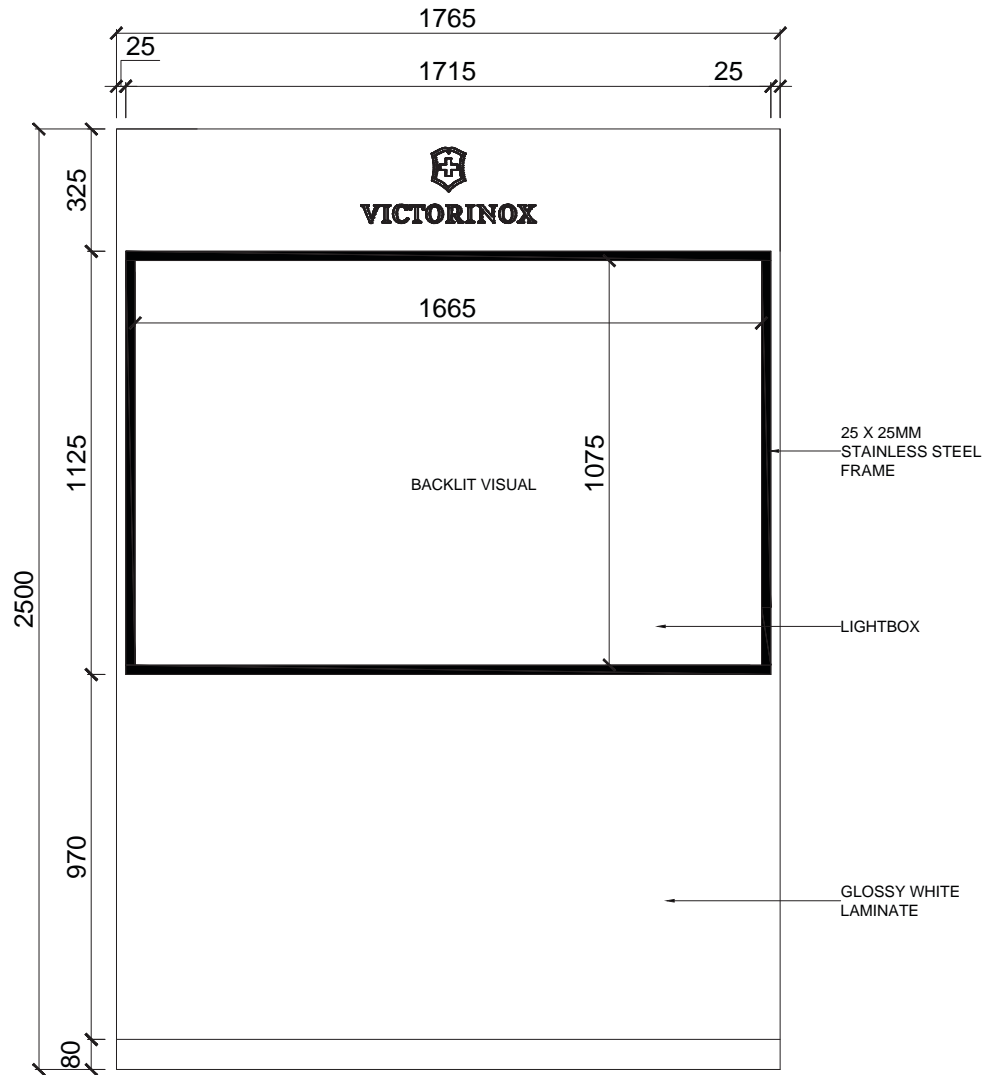

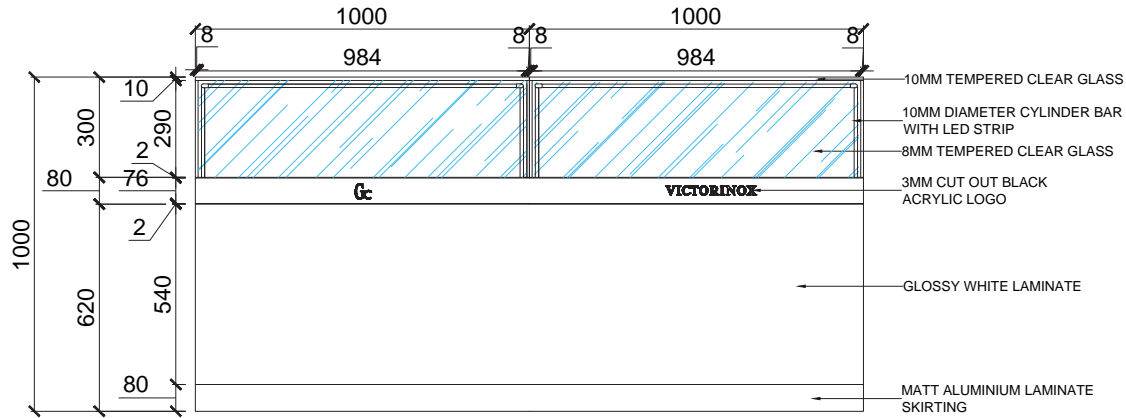

01 SECTION H
FRONT VIEW

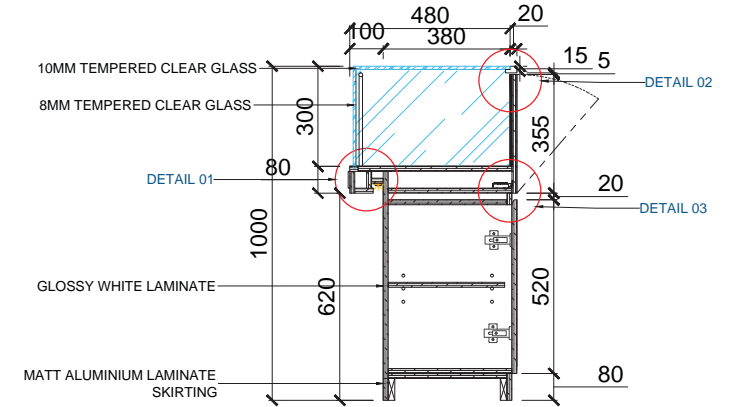

02 SECTION H
SIDE VIEW

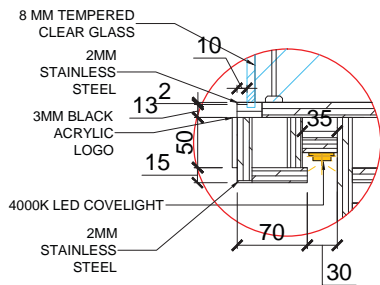

03 SECTION H DETAIL 01
SCALE 1:3

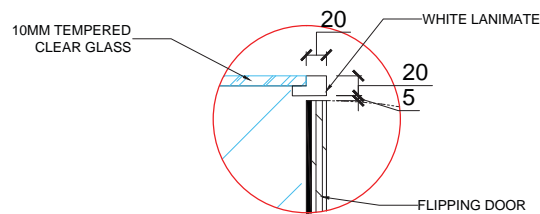

04 SECTION H DETAIL 02
SCALE 1:3

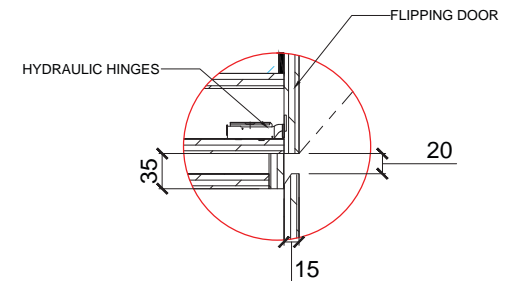

04 SECTION H DETAIL 03
SCALE 1:3



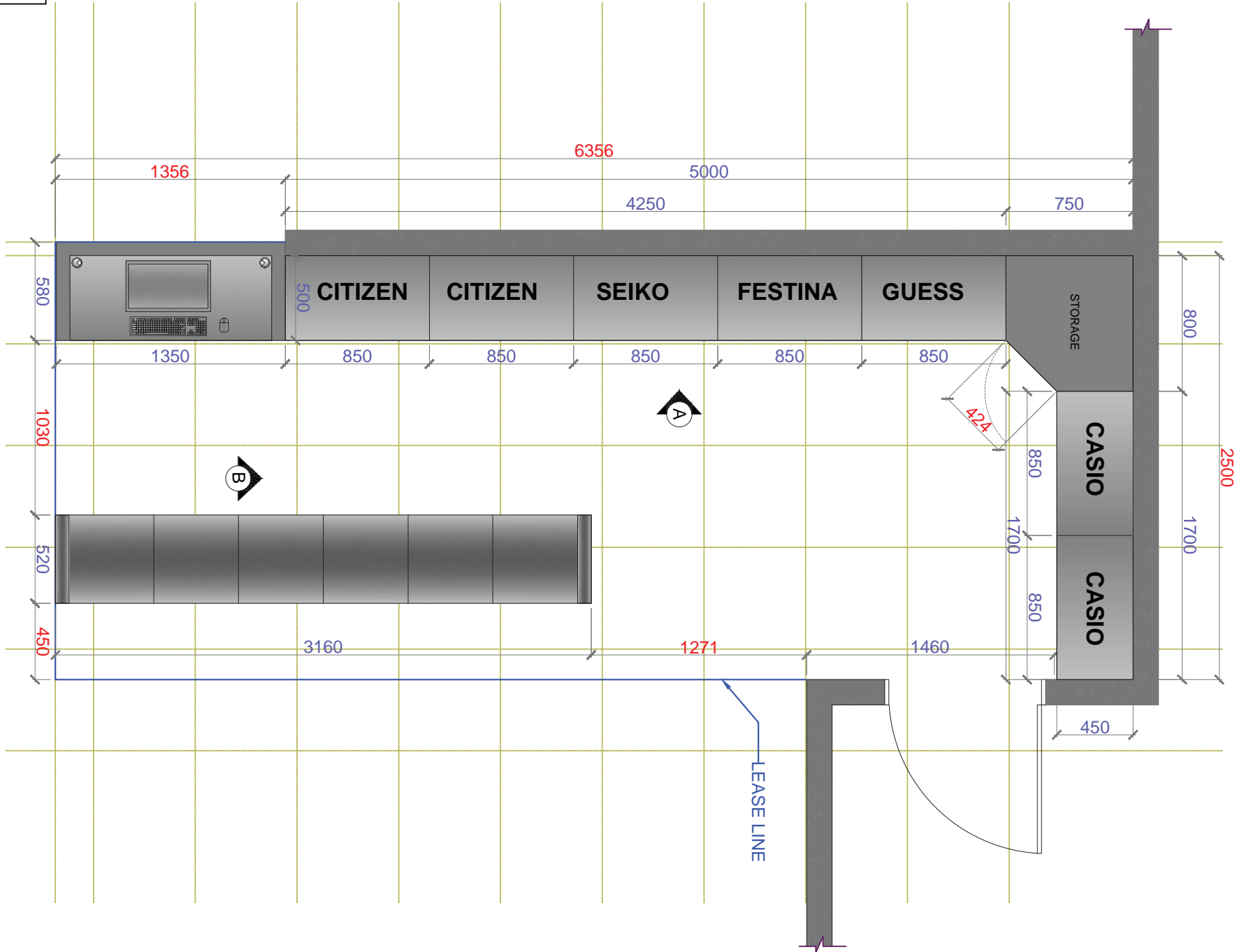



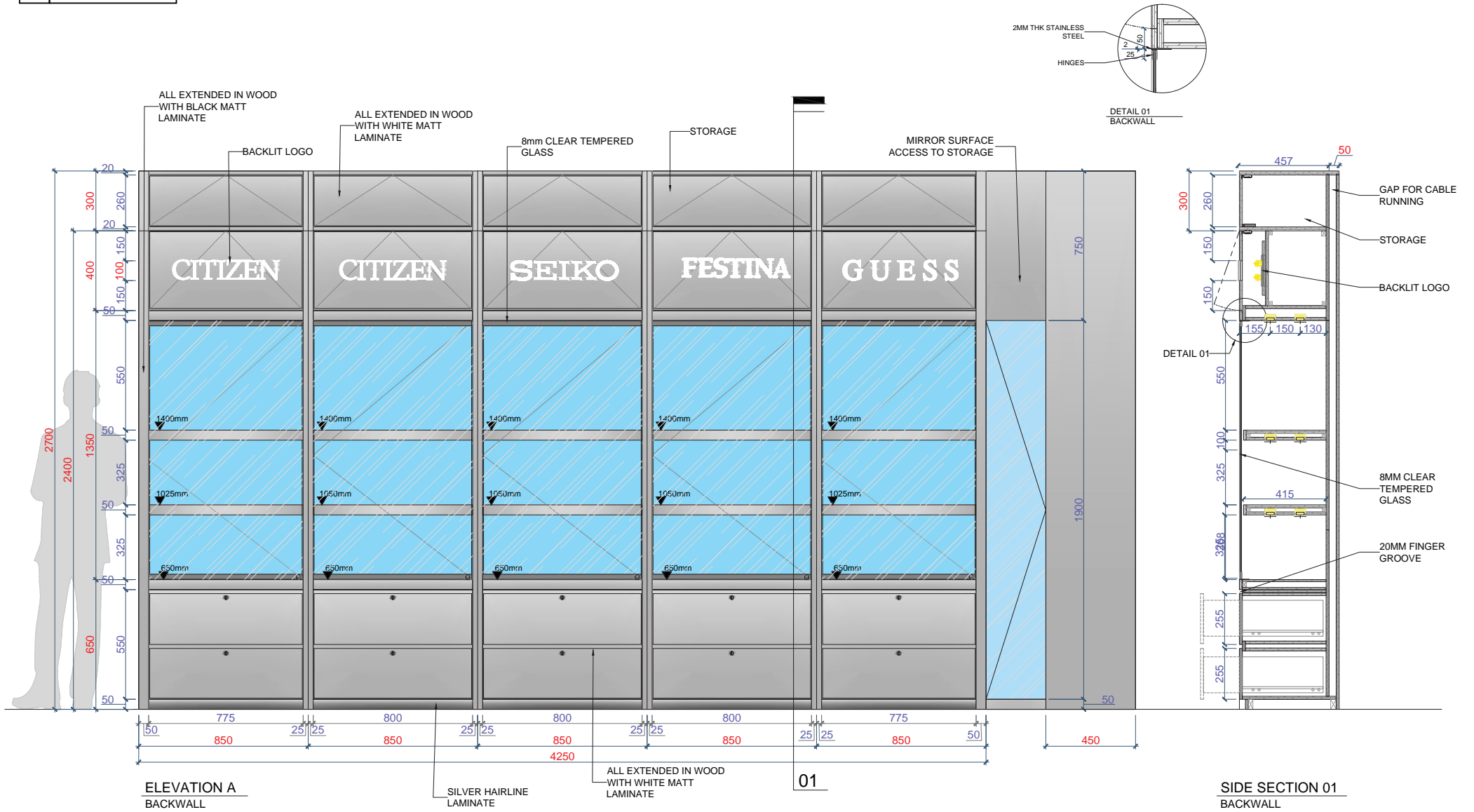

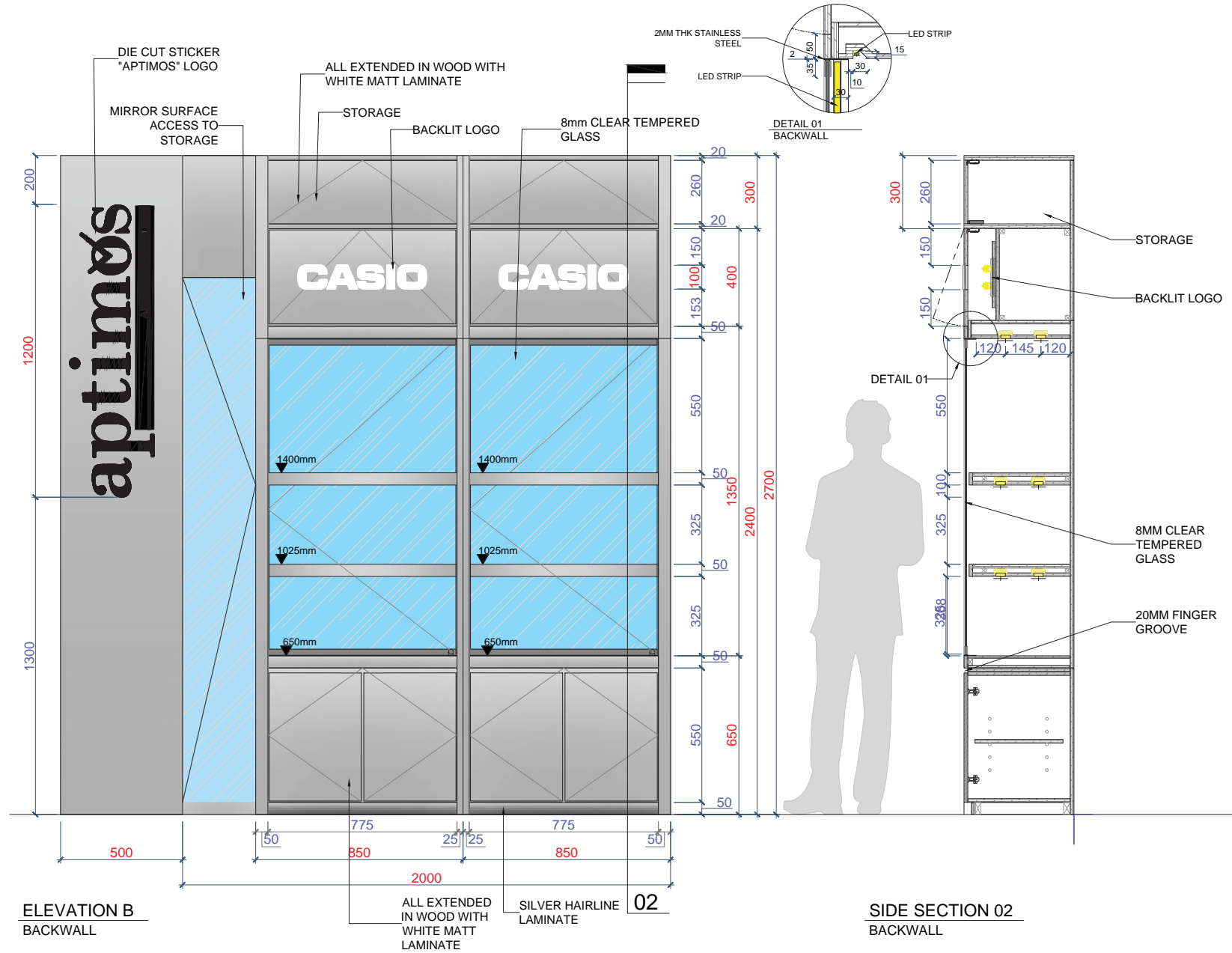

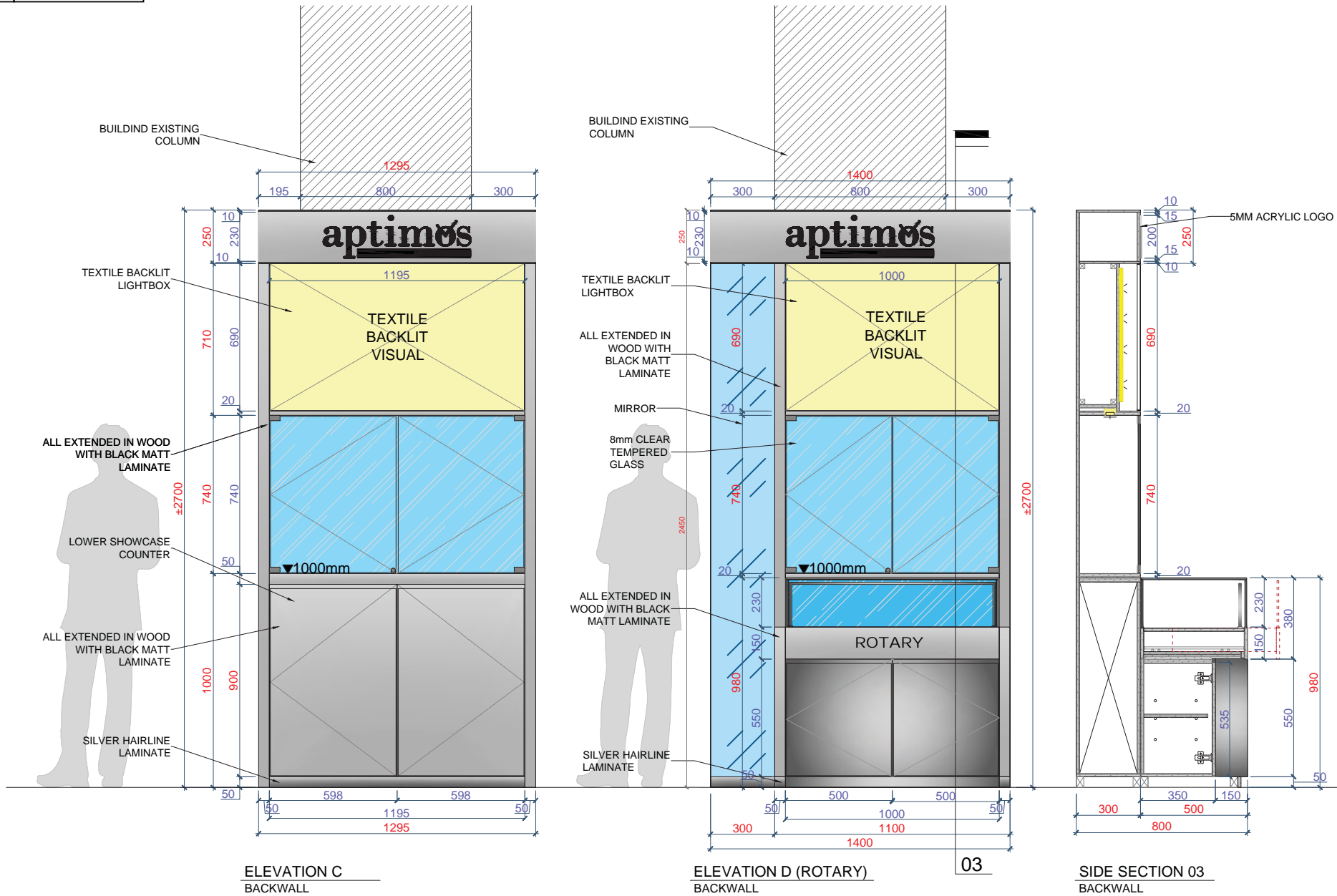

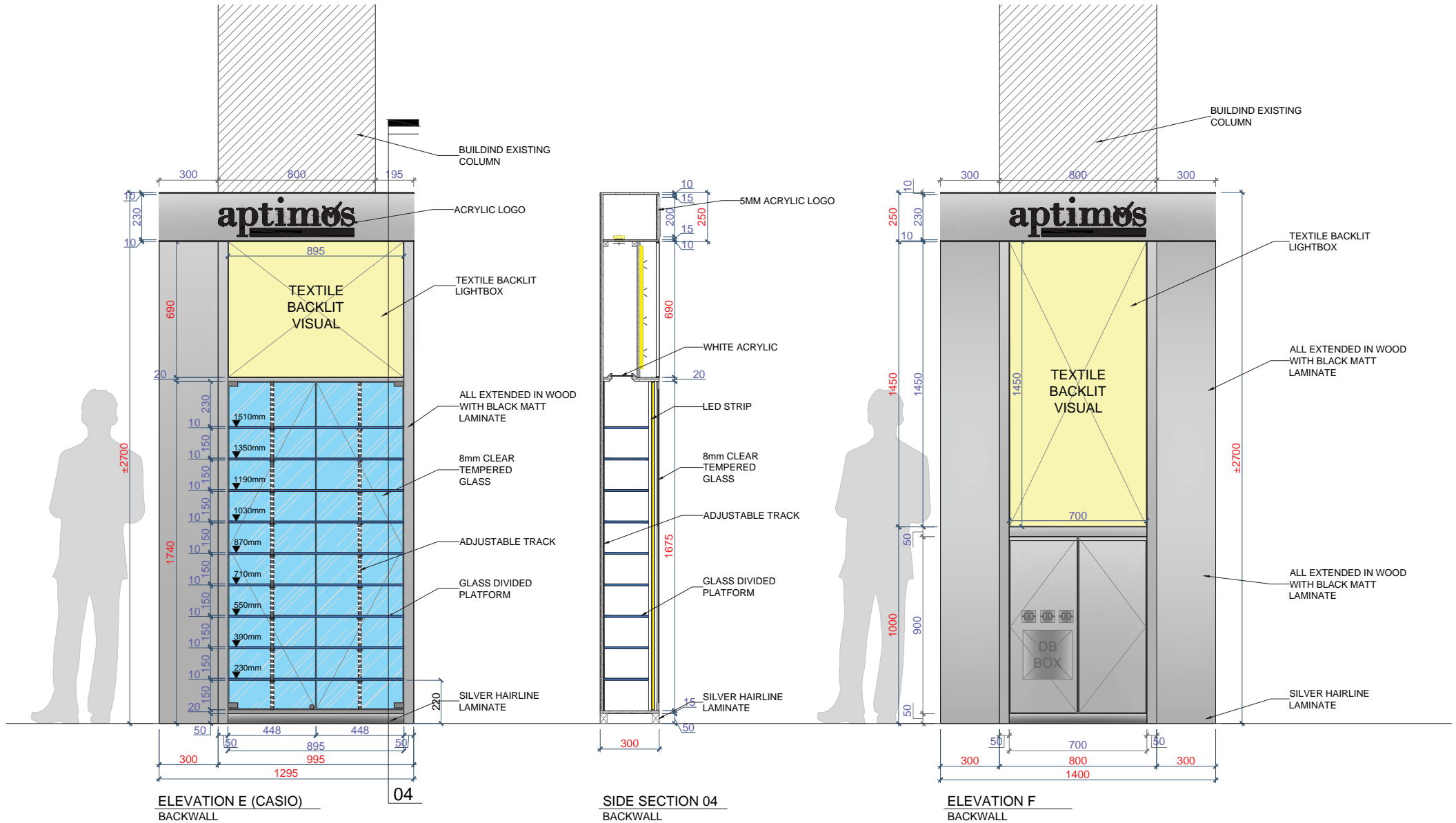



02 ELEVATION

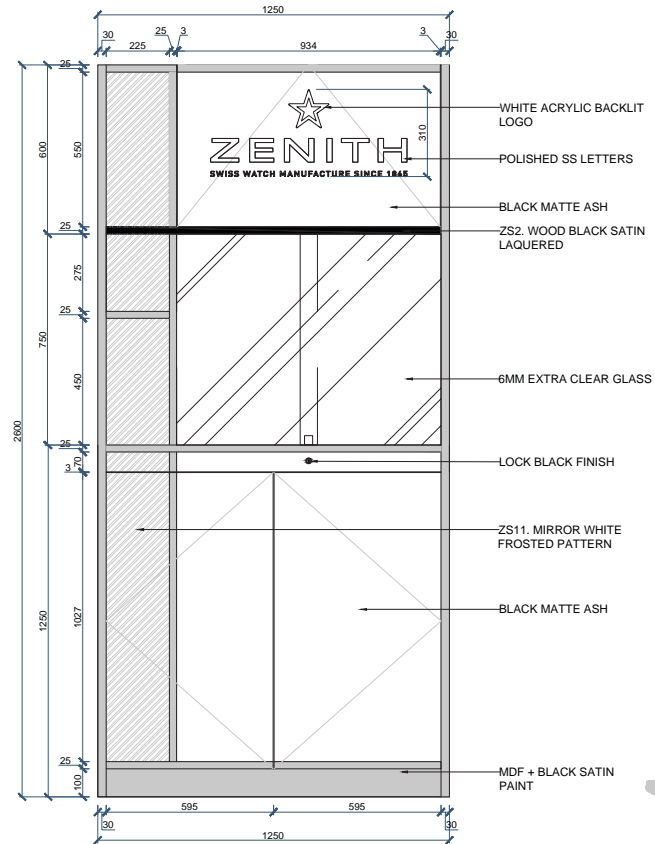

BACKWALL
FRONT VIEW

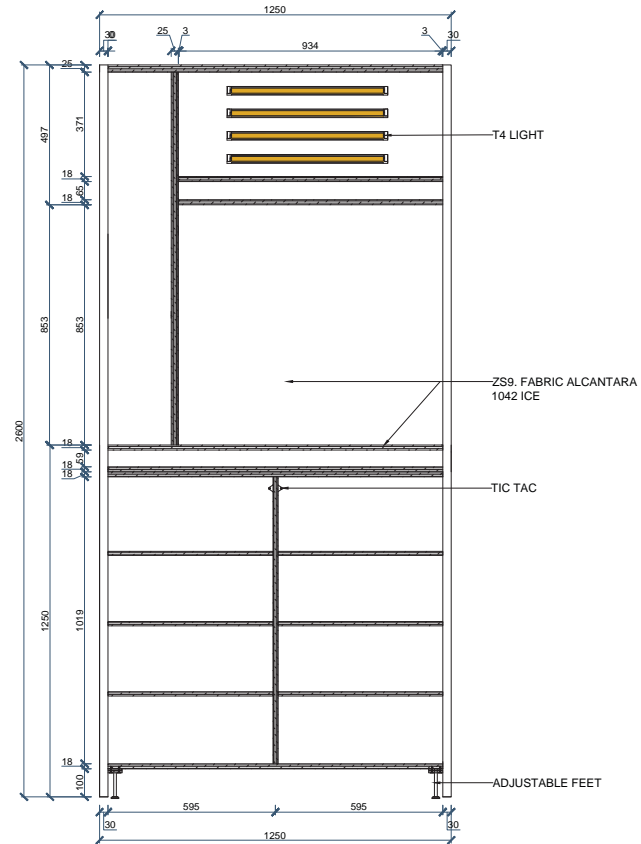

BACKWALL
FRONT SECTION

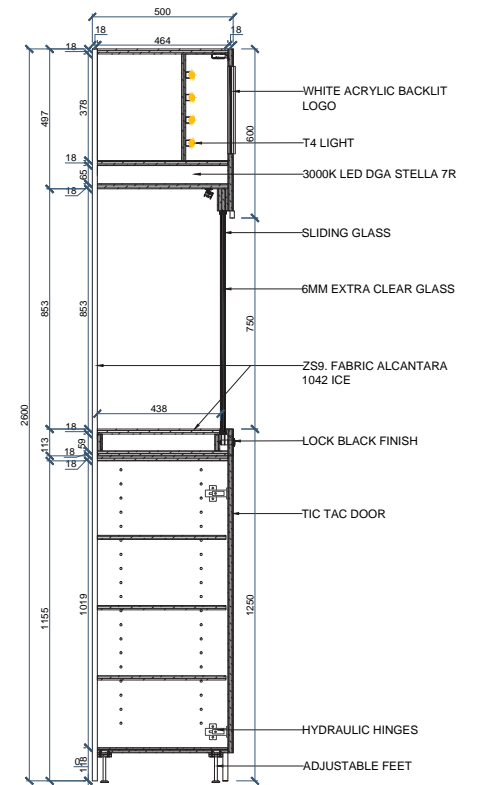

BACKWALL
SIDE SECTION

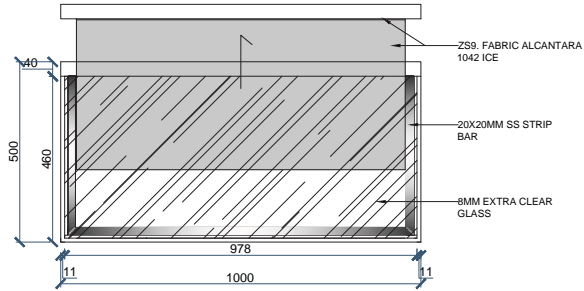

COUNTER
TOP VIEW

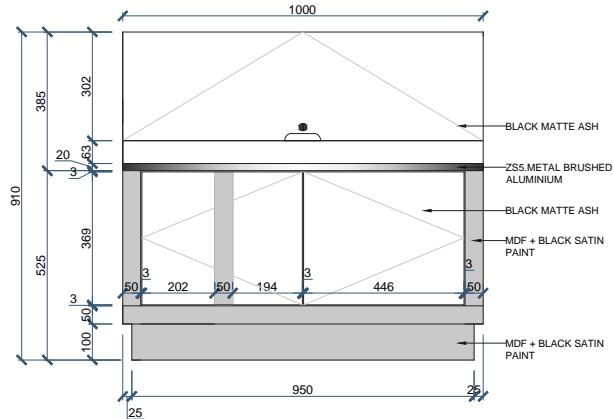

COUNTER
REAR VIEW

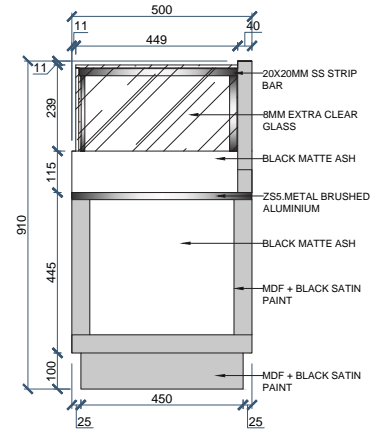

COUNTER
SIDE VIEW

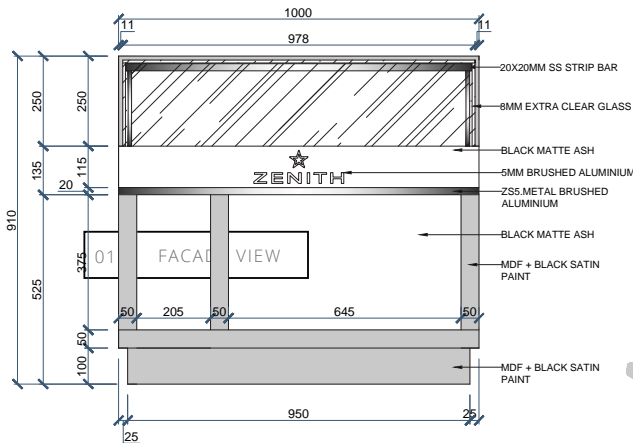

COUNTER
FRONT VIEW

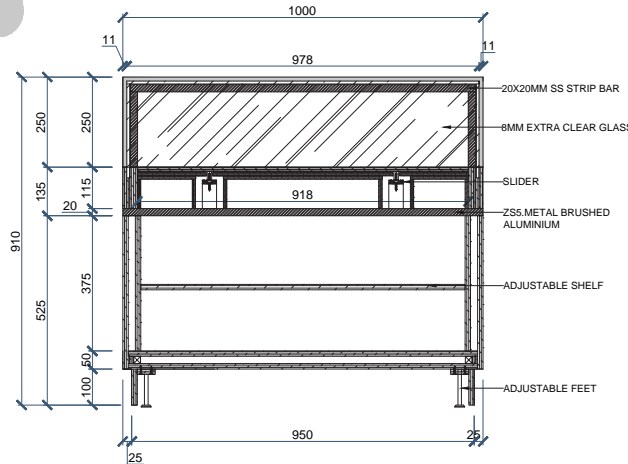

COUNTER
REAR SECTION

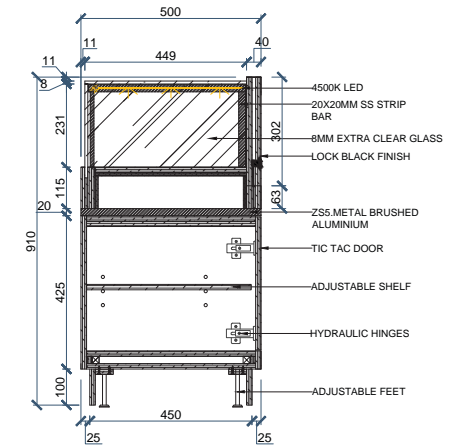

COUNTER
SIDE SECTION

01 LAY OUT PLAN

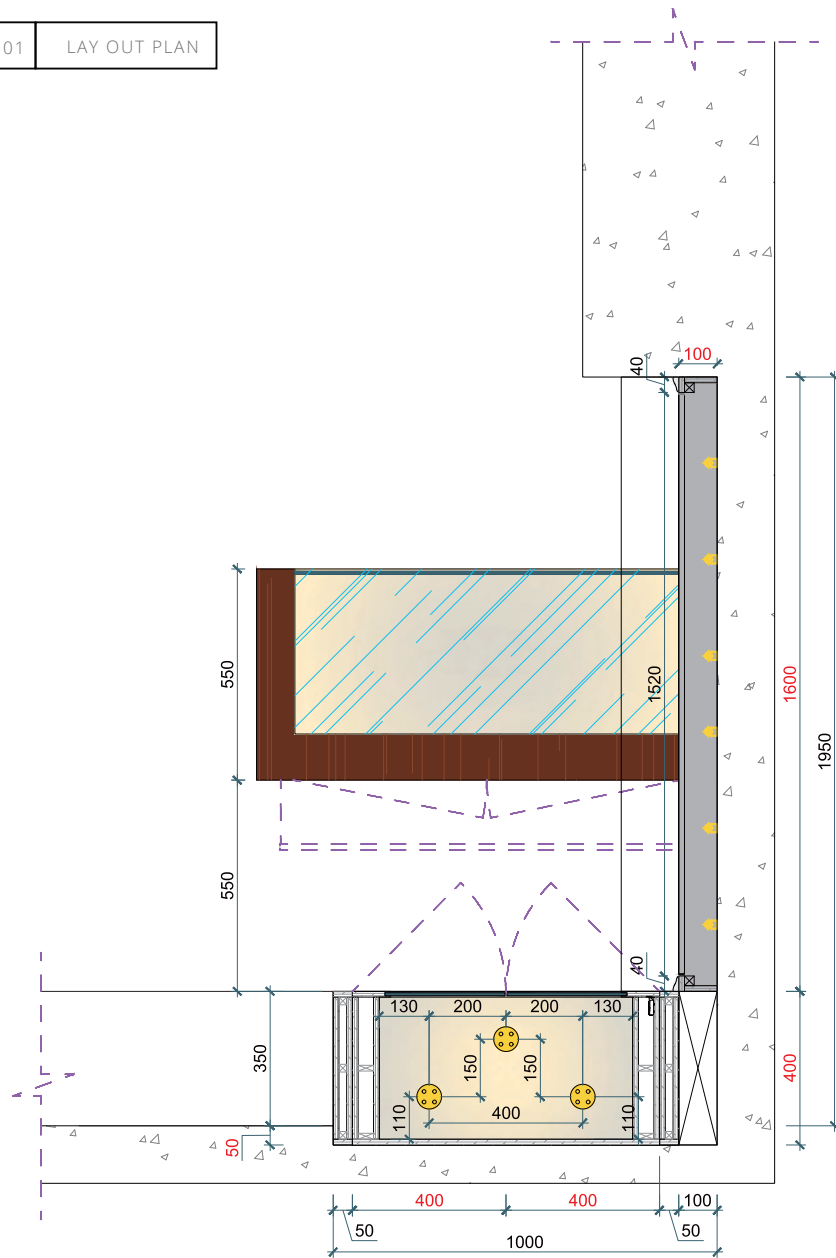

02 PERSPECTIVE VIEW



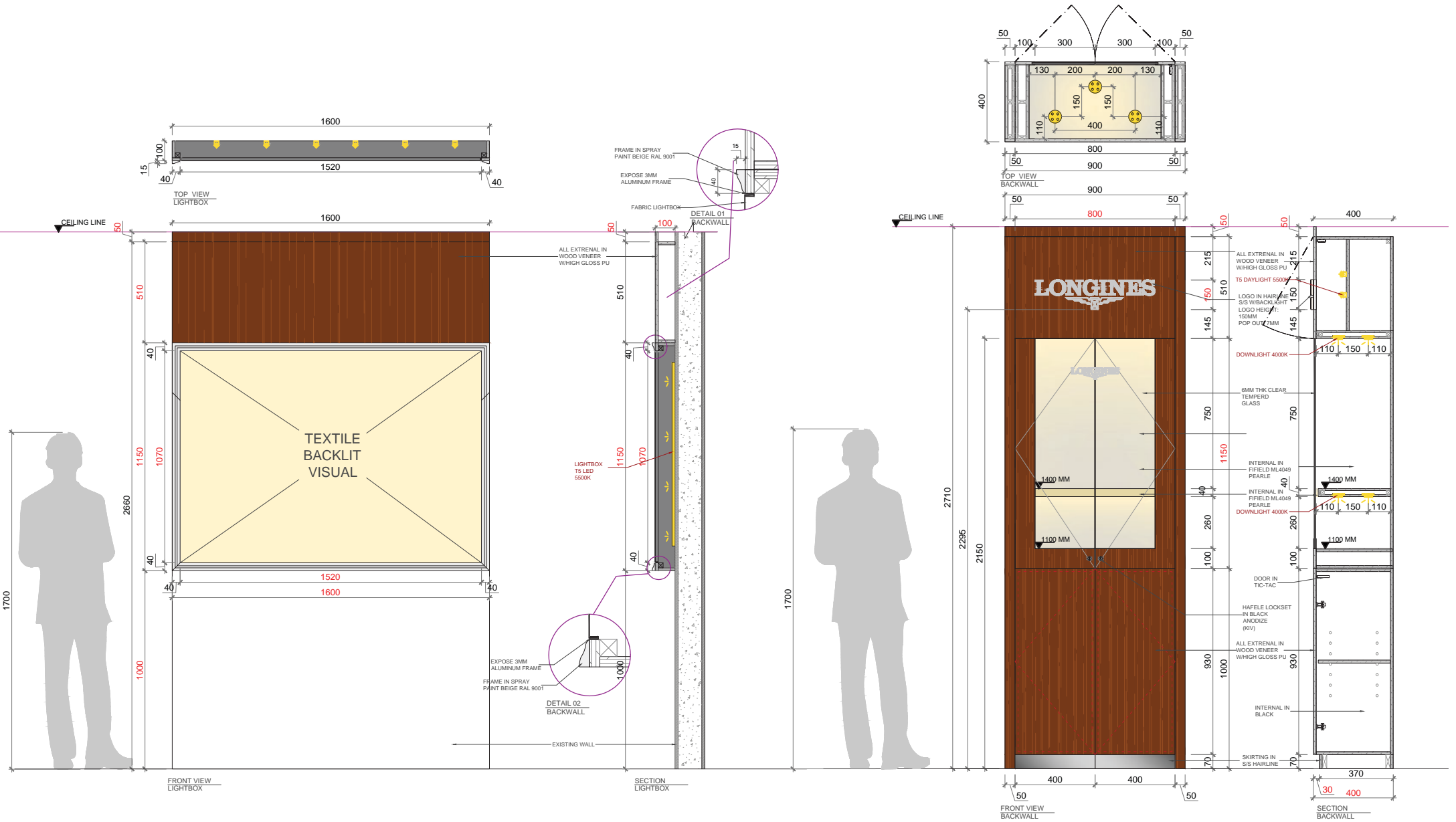

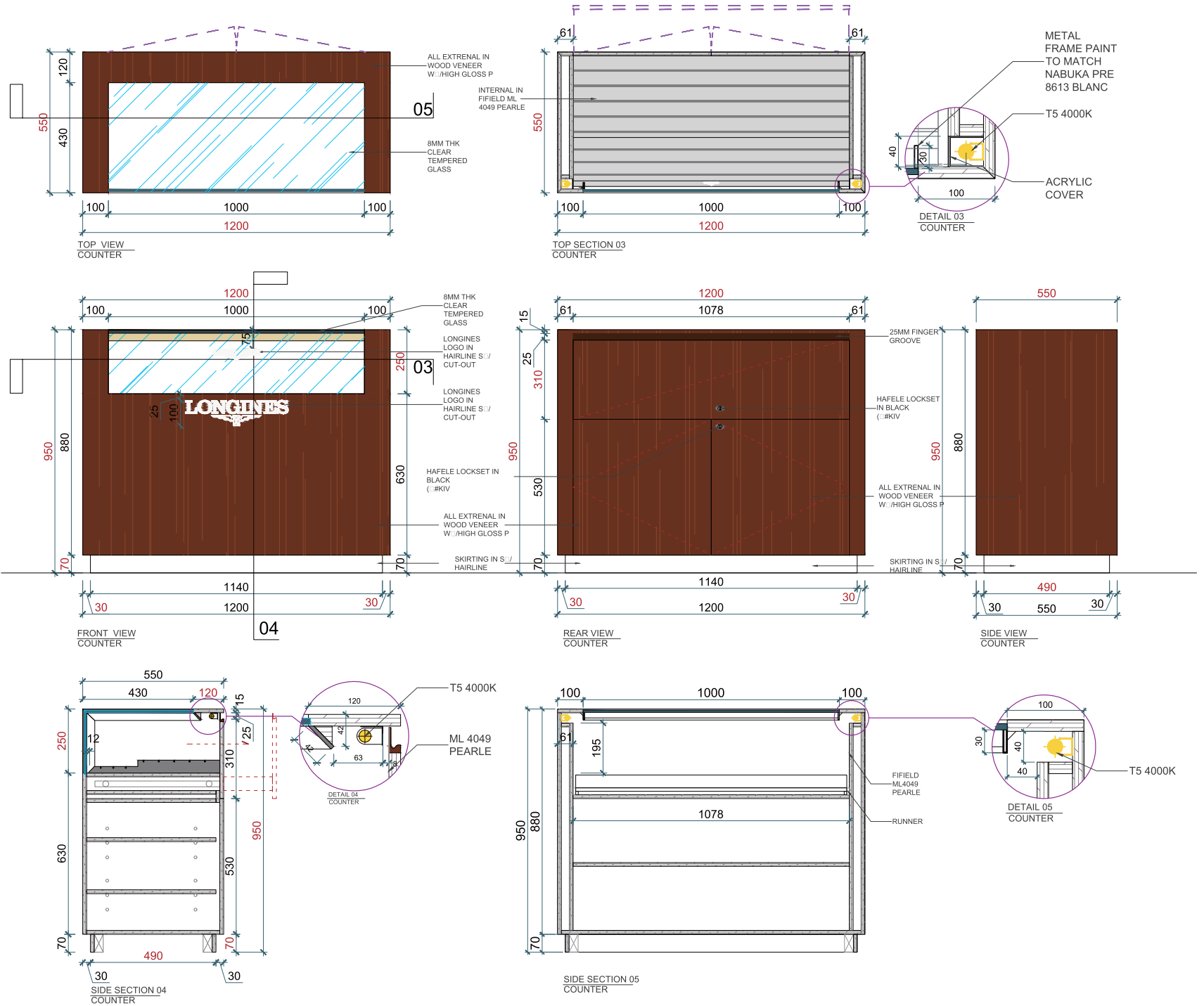



ROADSHOW/ EXHIBITION DESIGN

2017 - 2018

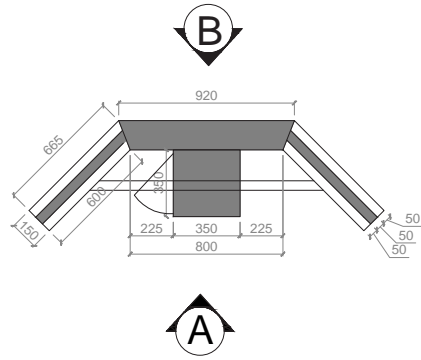

TOP VIEW
DISPLAY BACKWALL

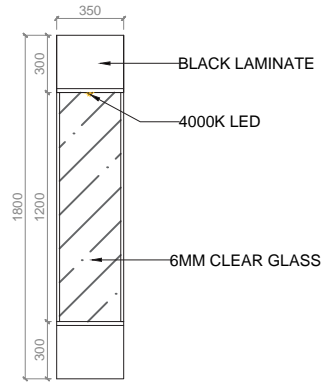

DETAIL 01
FRONT

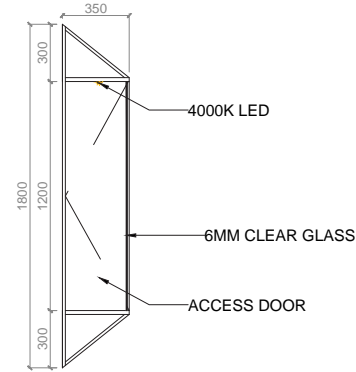

DETAIL 01
SIDE

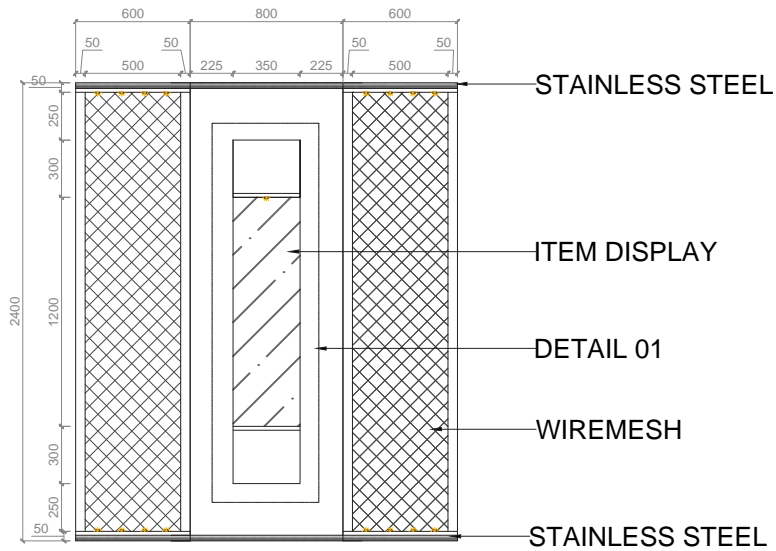

ELEVATION A
DISPLAY BACKWALL

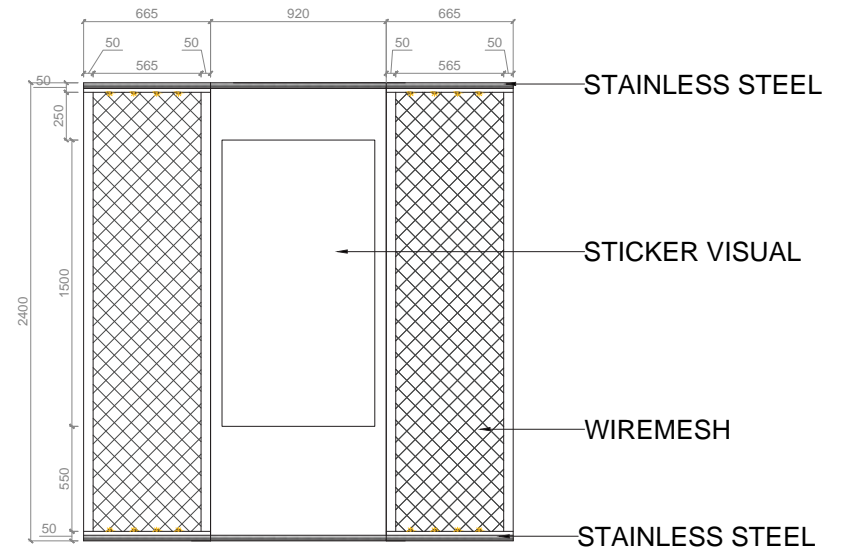

ELEVATION B
DISPLAY BACKWALL

05 ELEVATION

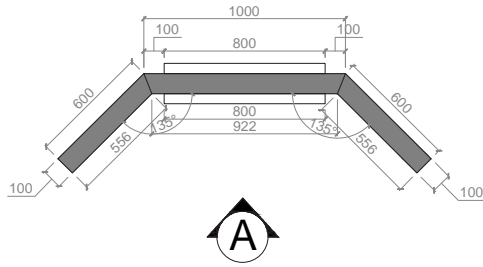

TOP VIEW
VISUAL BACKWALL

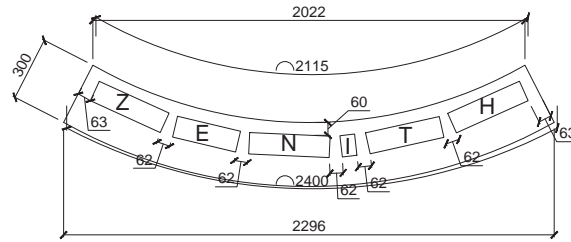

TOP VIEW
ZENITH 3D SIGNATURE

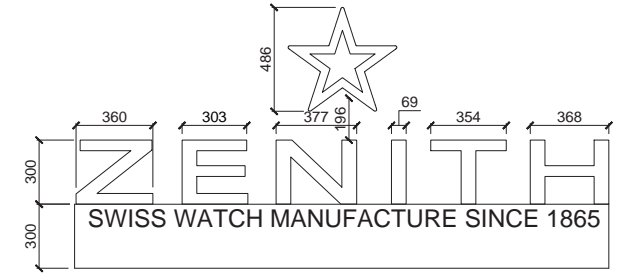

FRONT VIEW
ZENITH 3D SIGNATURE

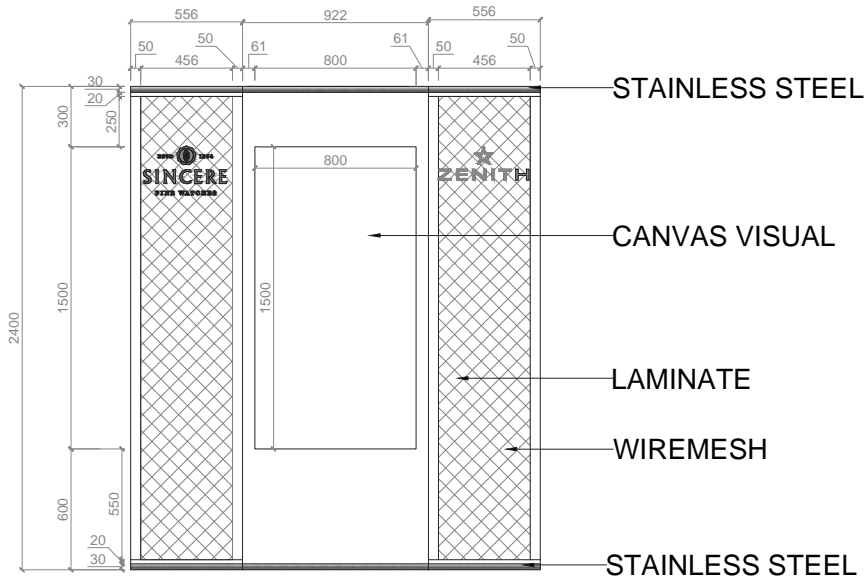

ELEVATION A
DISPLAY BACKWALL

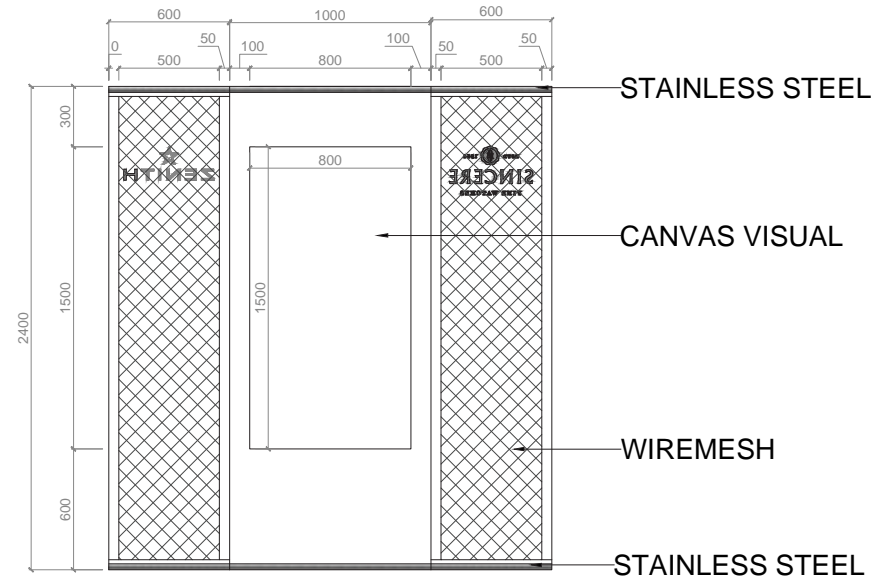

ELEVATION B
DISPLAY BACKWALL





Brand:
LONGINES

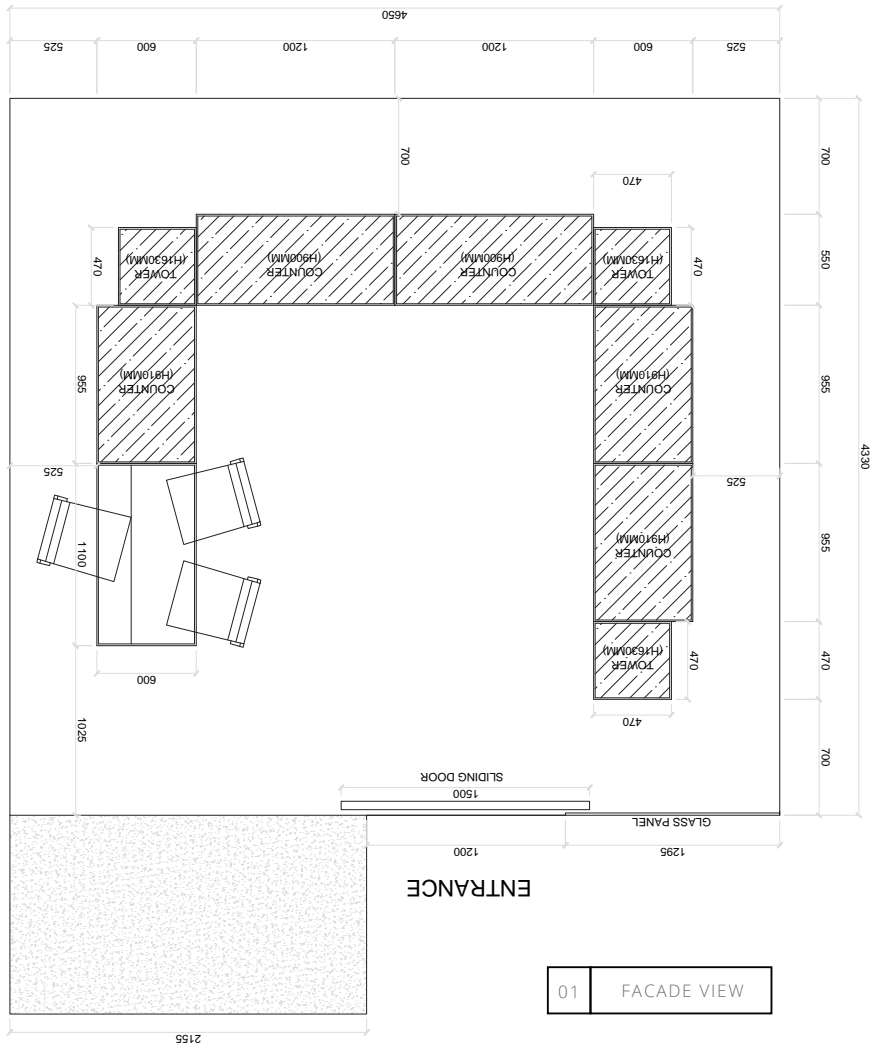

01 FACADE VIEW



01 FACADE VIEW

Location:
MARINA BAY SAND

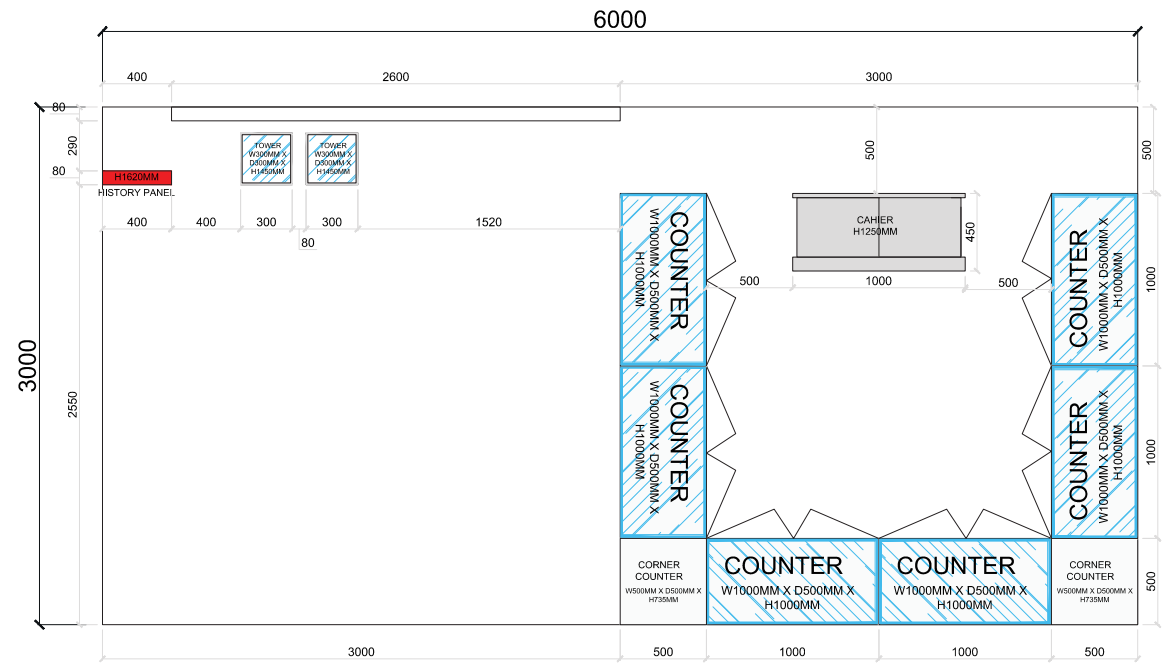

FRONT

02 ELEVATION

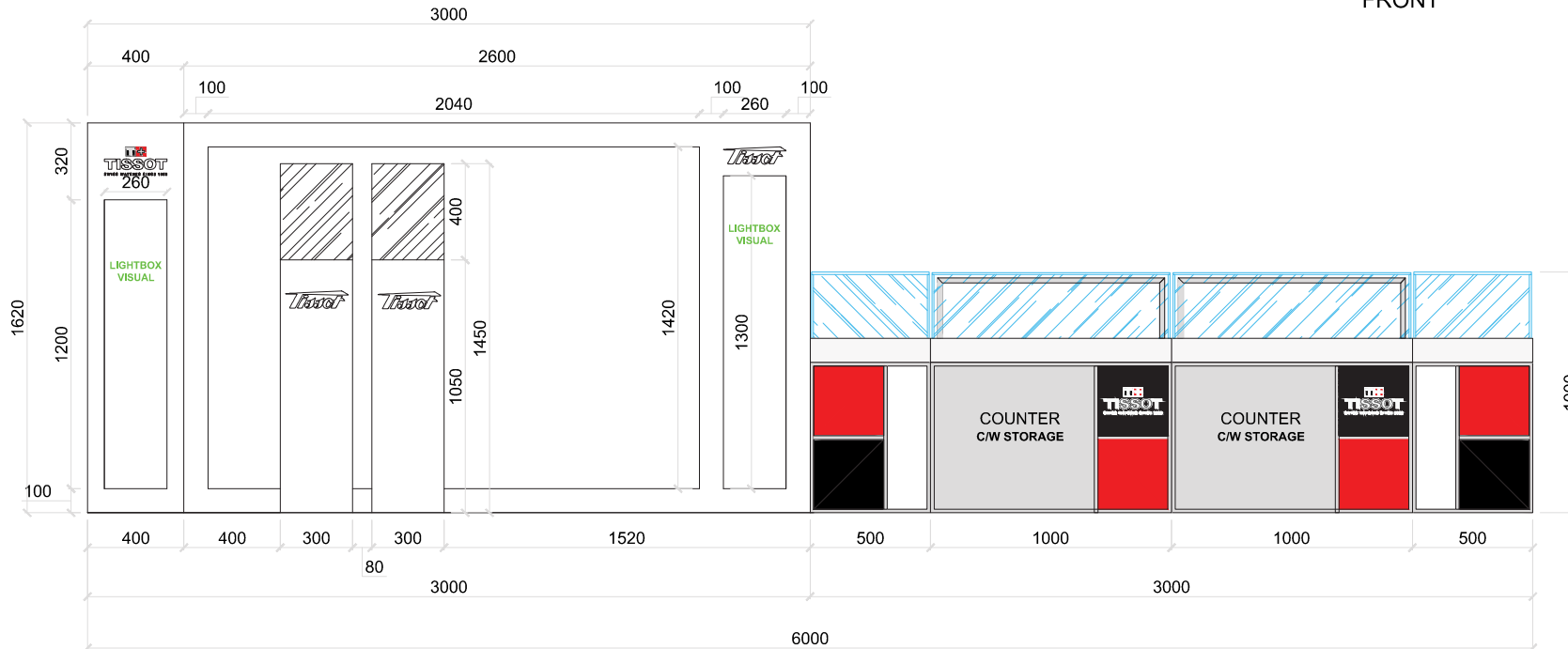

FRONT ELEVATION

03 PERSPECTIVE VIEW



04 ACTUAL PHOTO





04 | ACTUAL PHOTO



01 LAY OUT PLAN

02 ISOMETRIC VIEW

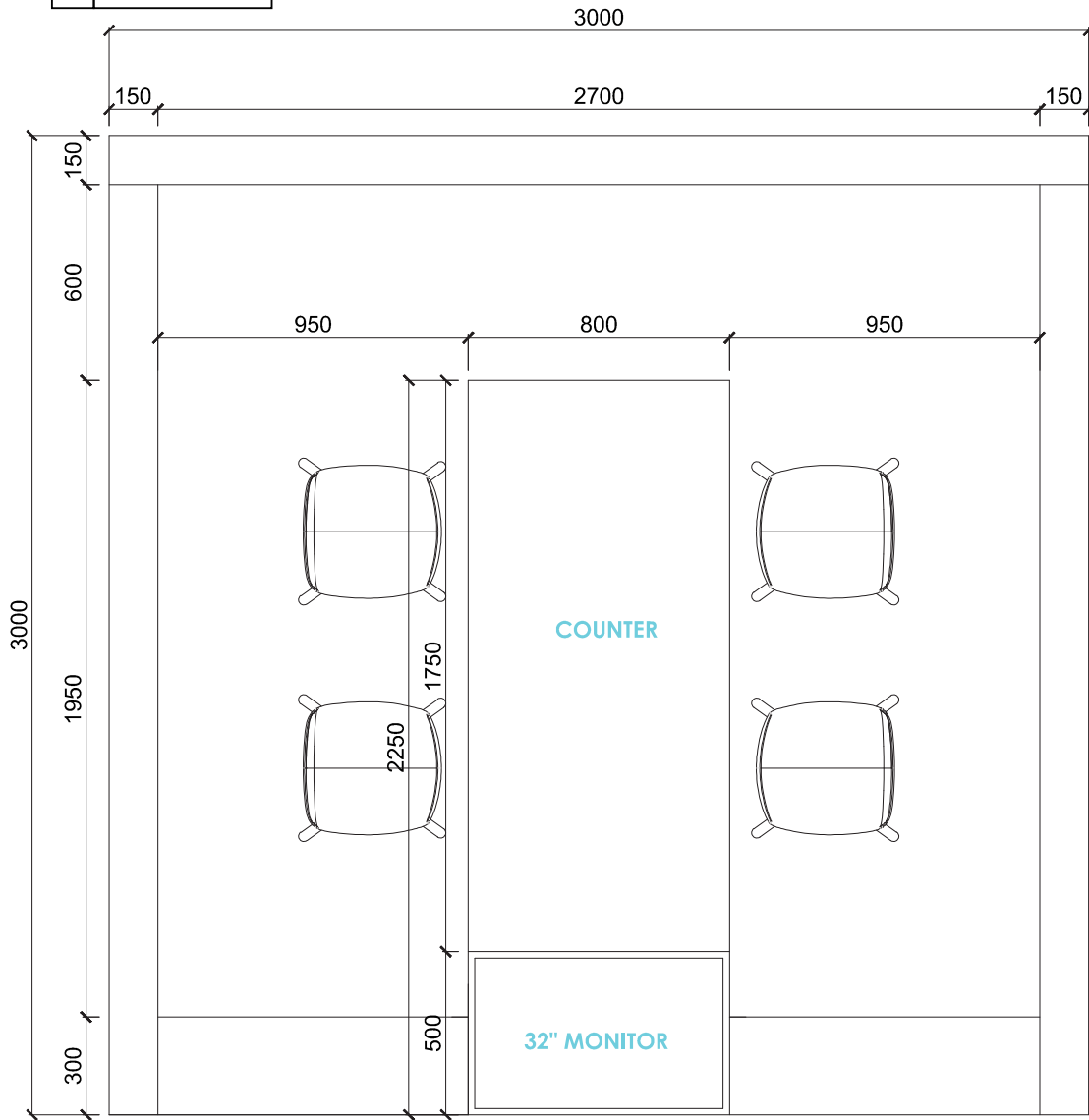

Location:
CHANGI AIRPORT T3-SHILLA BOUTIQUE

03 ELEVATION

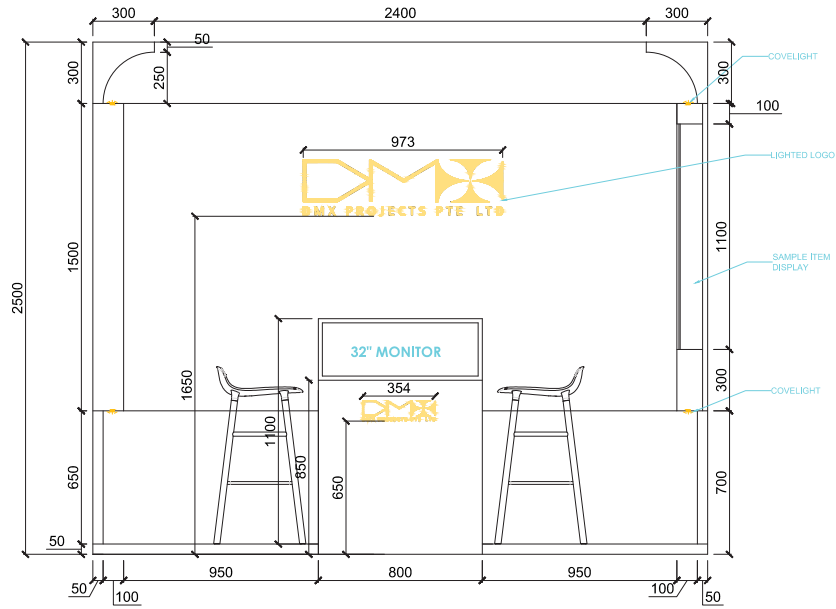

FRONT VIEW

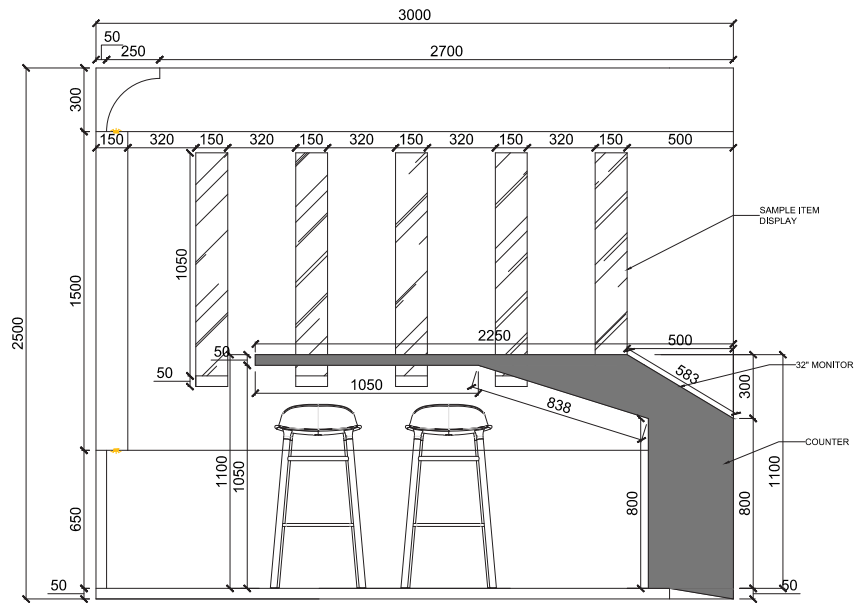

SIDE SECTION

04 PERSPECTIVE VIEW



Location:
CHANGI AIRPORT T3-SHILLA BOUTIQUE

05 | ACTUAL PHOTO



06 | FLYER



01 LAY OUT PLAN

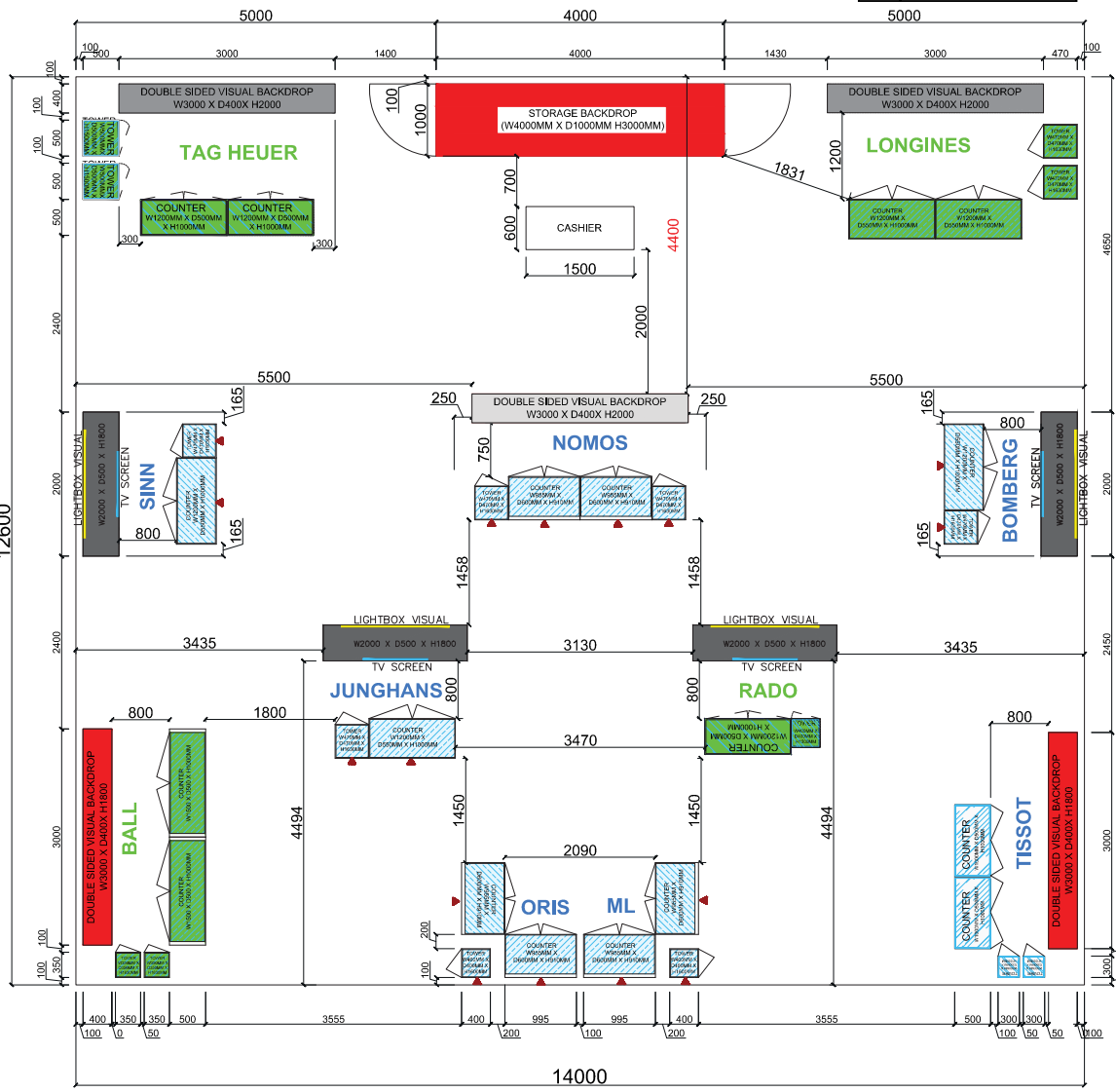

LEGEND:

- NEW BACKWALL
- ▲ LOGO DIE CUT STICKER
- BY CLIENT
- EXISTING



02 ISOMETRIC VIEW



03 PERSPECTIVE VIEW

04 ACTUAL PHOTO



01 LAY OUT PLAN

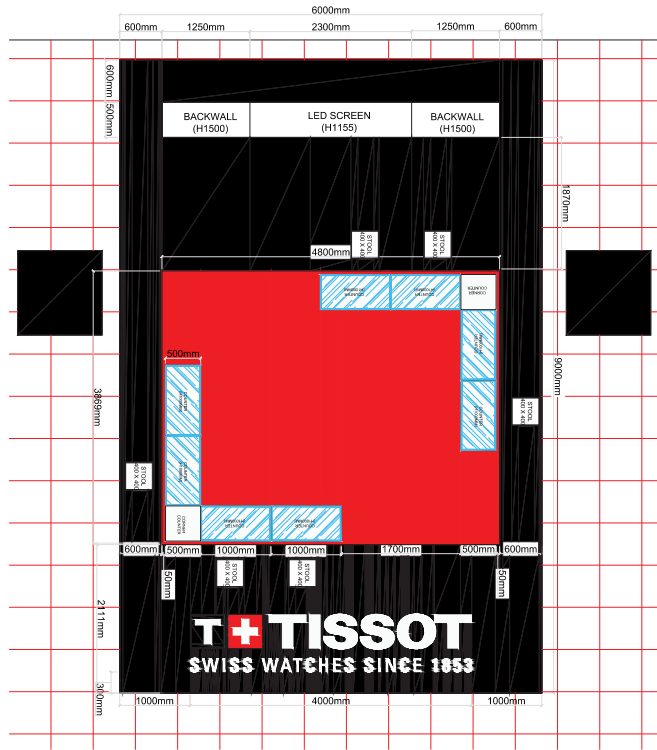

02 PERSPECTIVE VIEW



03 ACTUAL PHOTO



01 LAY OUT PLAN

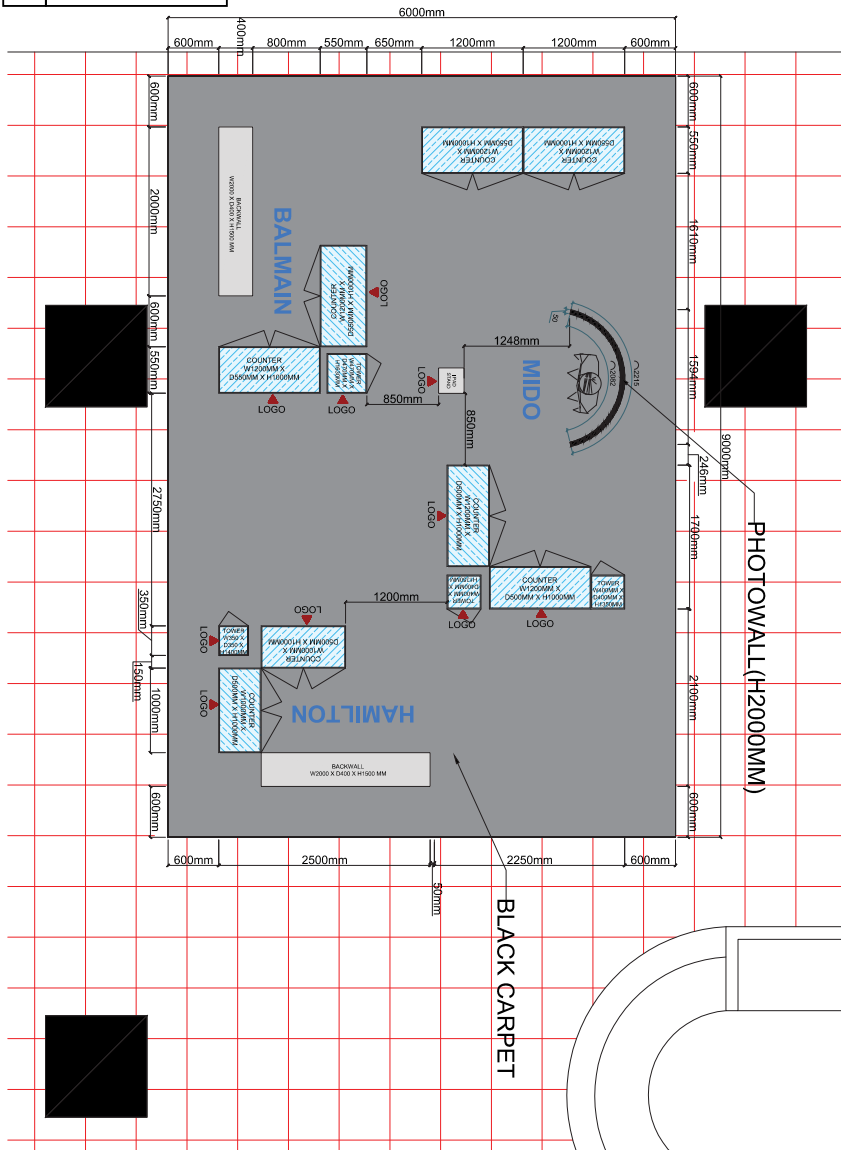

02 ISOMETRIC VIEW

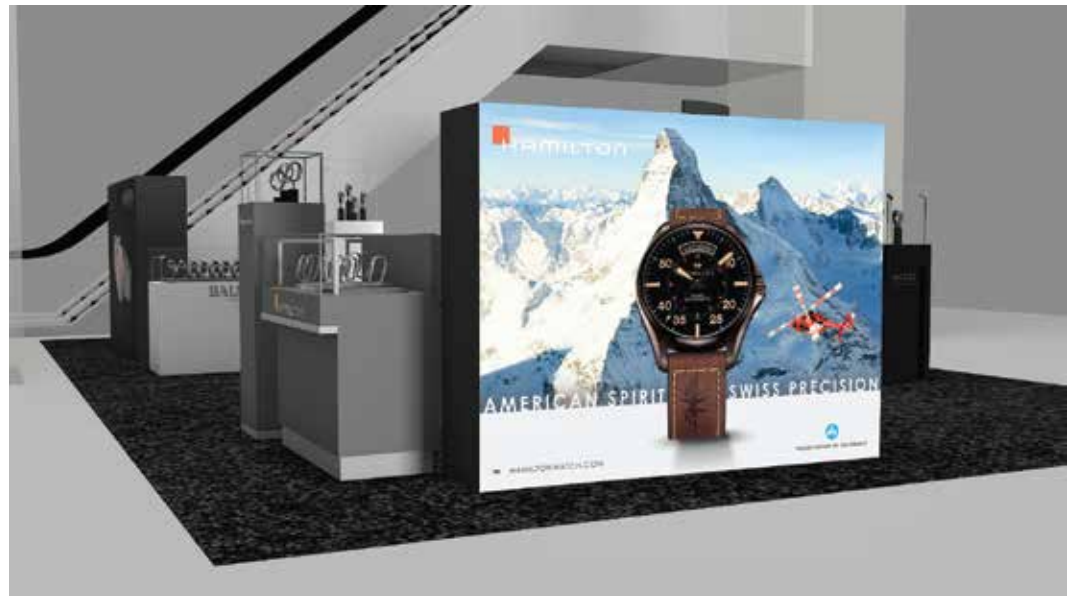
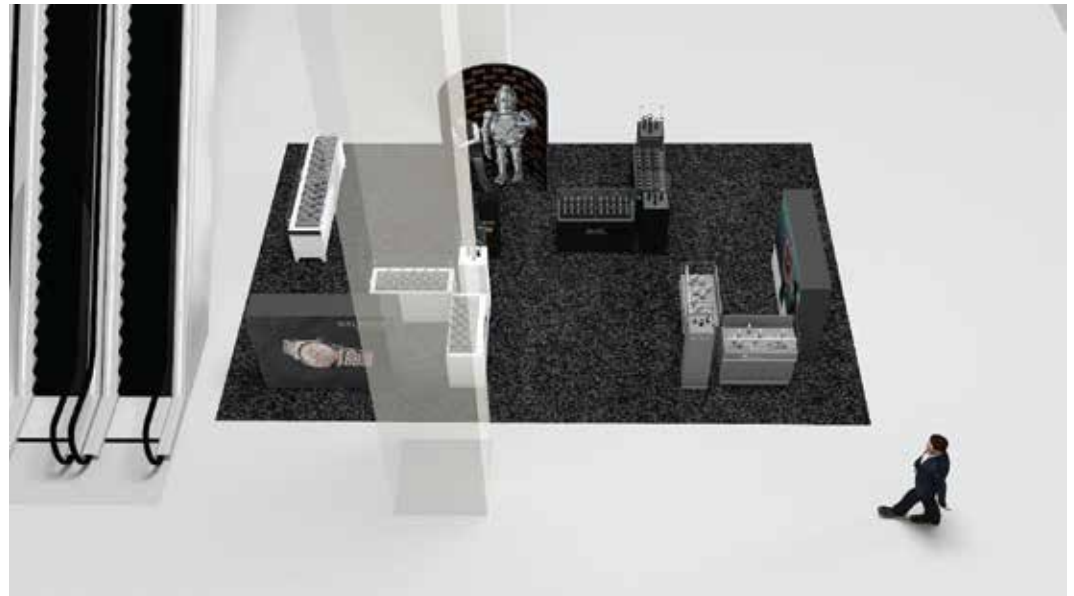

03 PERSPECTIVE VIEW



EXHIBITION DESIGN

Location:
VIVO CITY EAST BOULEVARD B



01 LAY OUT PLAN

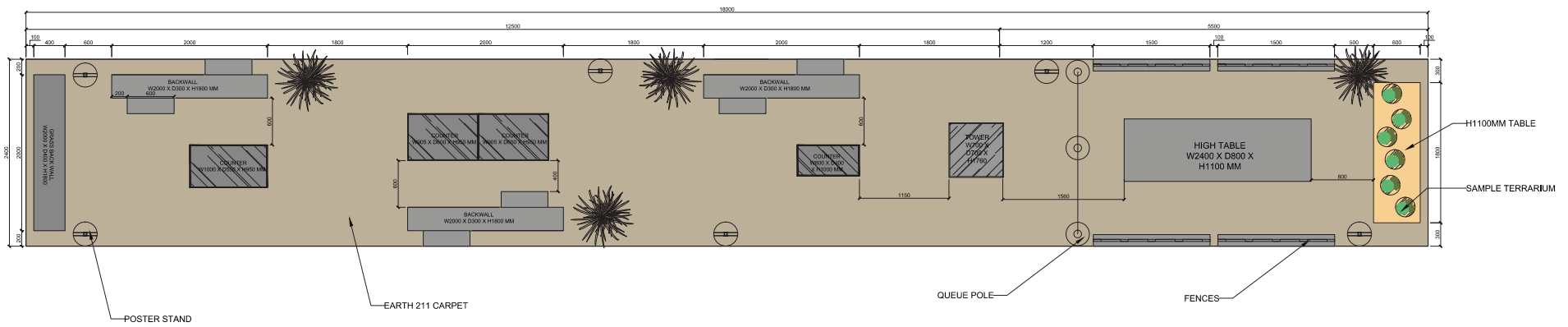

02 PERSPECTIVE VIEW

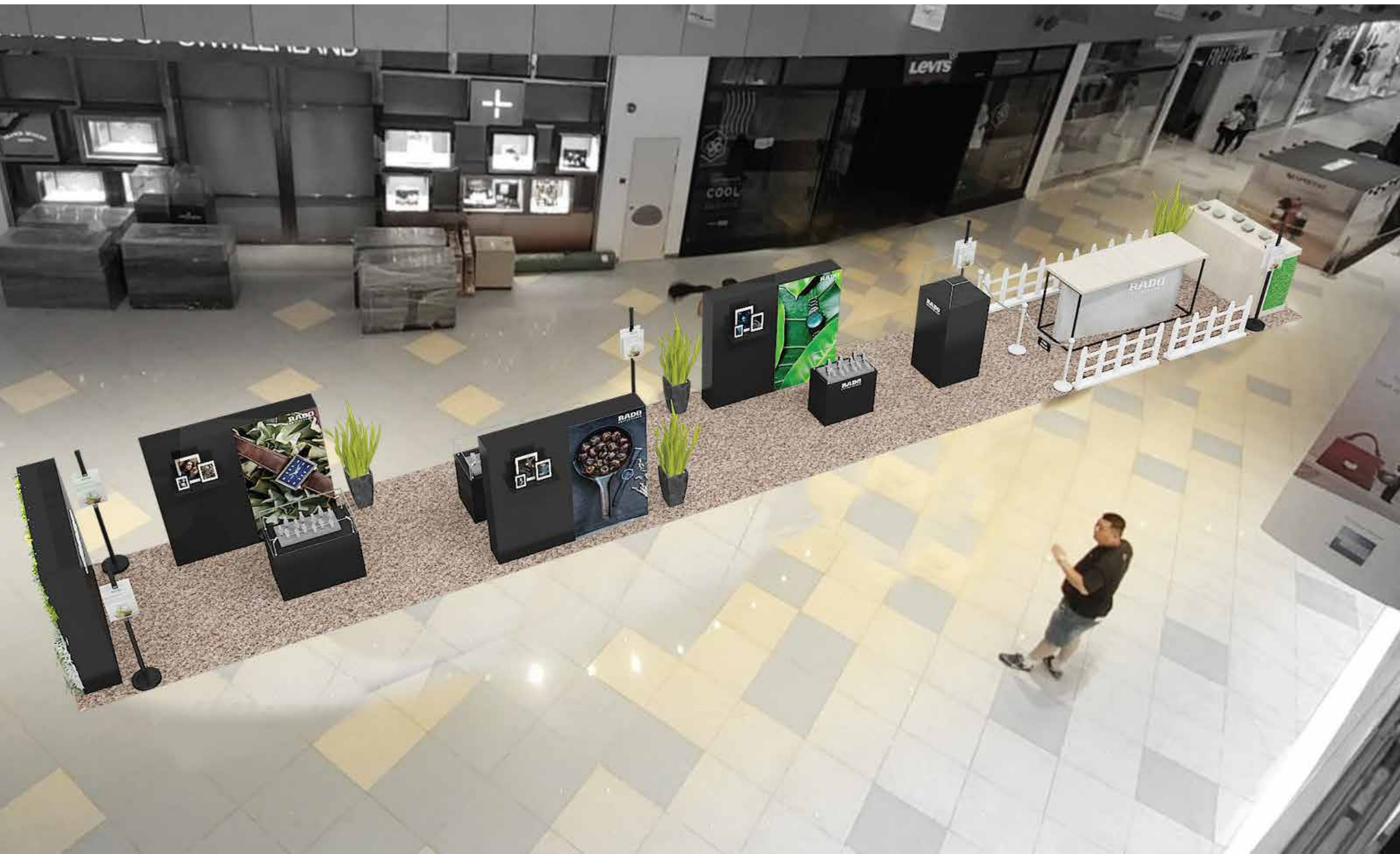

03 FRONT VIEW



04 REAR VIEW

VICTORIA STREET

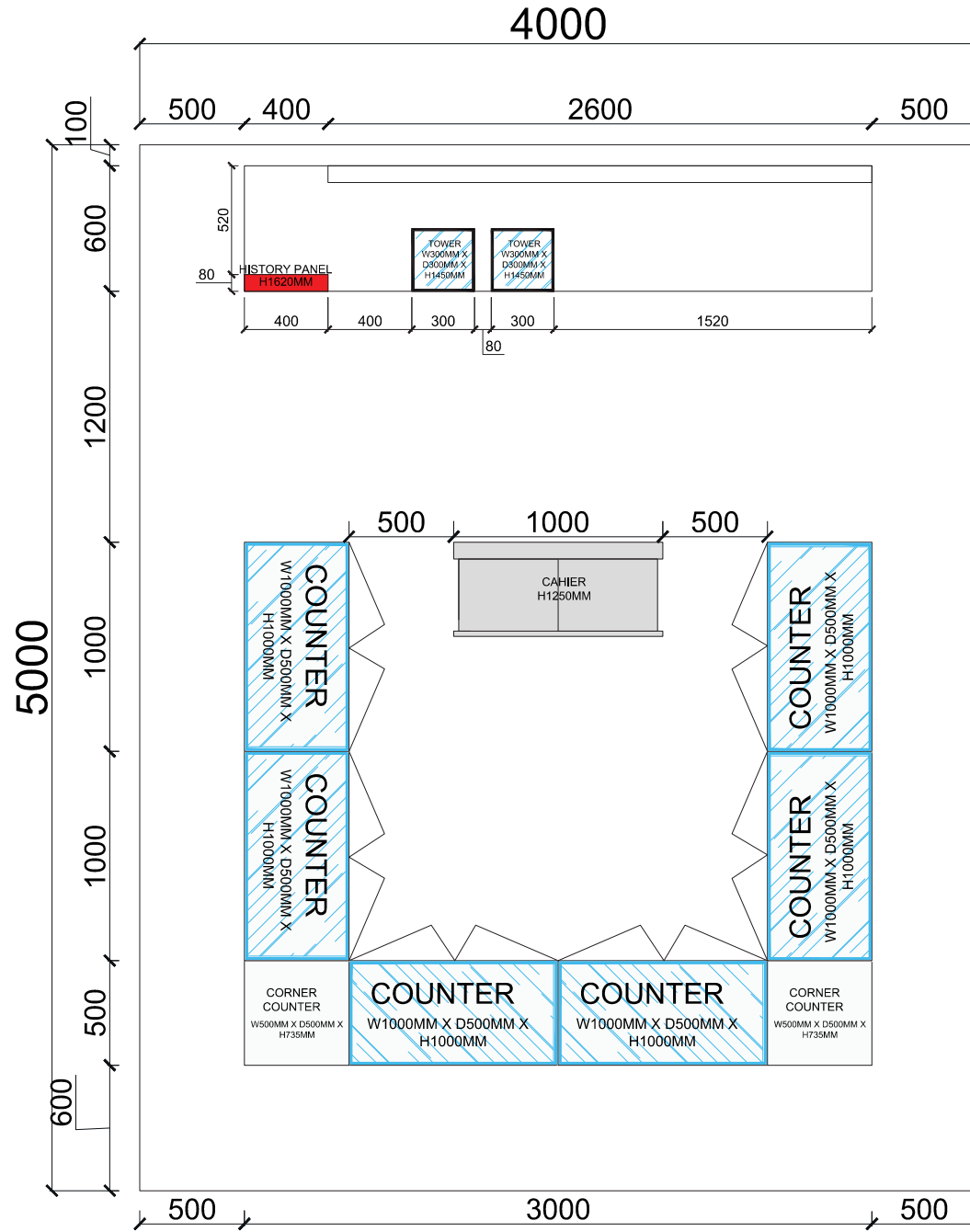

NORTH BRIDGE ROAD



01 LAY OUT PLAN

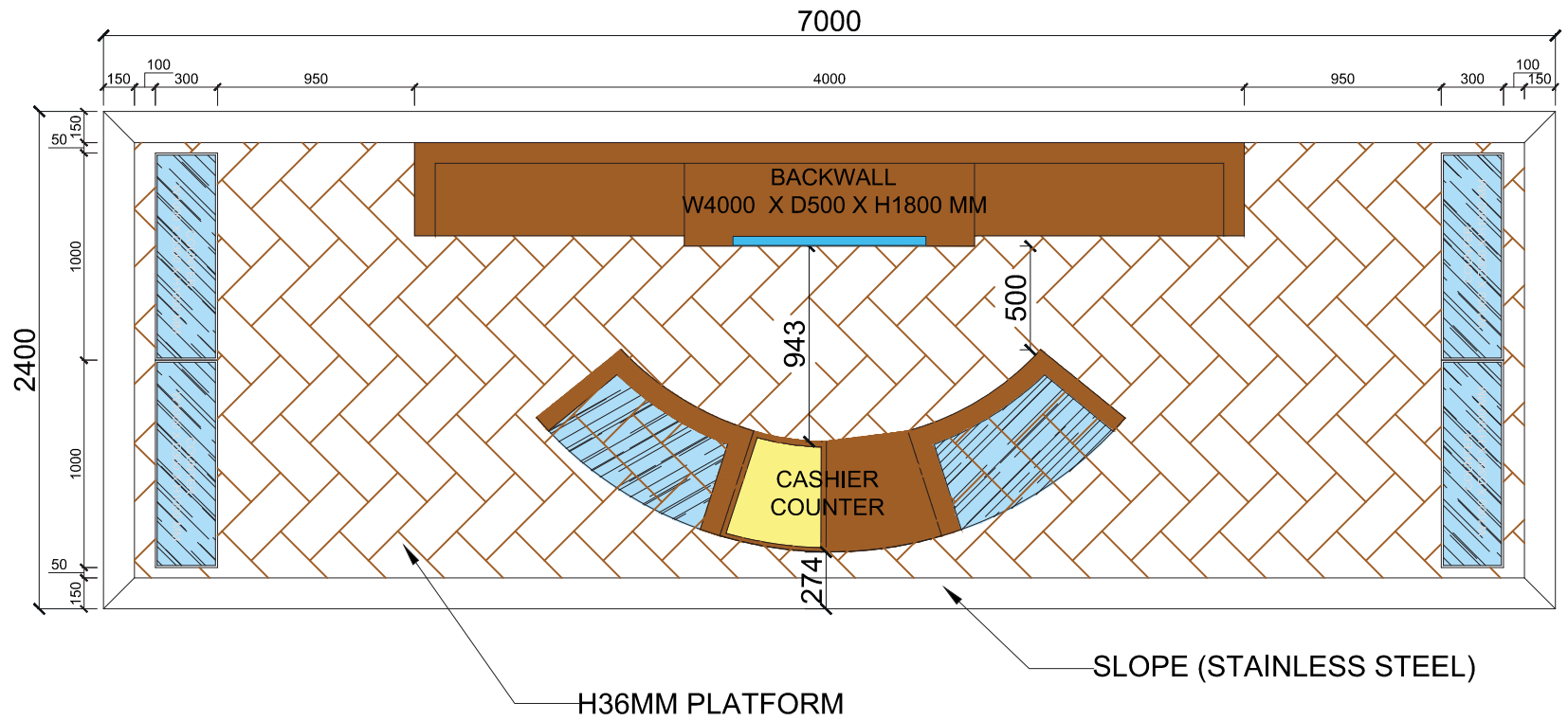

02 FRONT VIEW













WINDOW DISPLAY DESIGN

2017- 2018

01 PERSPECTIVE VIEW

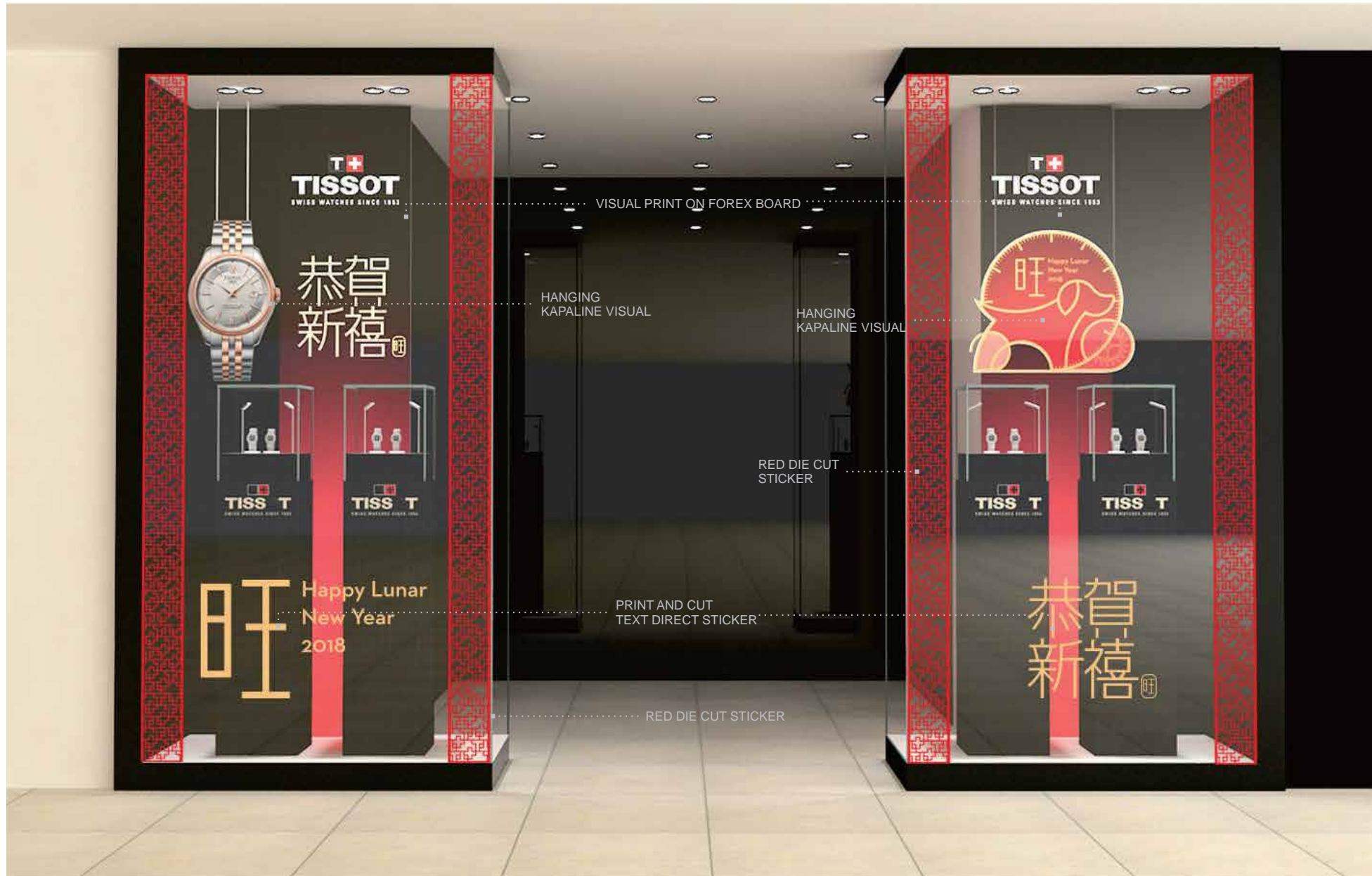

Location:
TISSOT BOUTIQUE - MARINA BAY SAND

01 PERSPECTIVE VIEW



02 ACTUAL PHOTO





01 PERSPECTIVE VIEW



HANGING CLEAR ACRYLIC
WITH DIE CUT STICKER

REVERSE STICKER

HANGING VISUAL
KAPALINE

RED DIE CUT STICKER

VISUAL PRINT ON
FOREX BOARD

PRINT & CUT STICKER

PRINT & CUT STICKER

Location:
TISSOT BOUTIQUE - ION ORCHARD





Location:
TISSOT BOUTIQUE - PLAZA SINGAPURA

01 PERSPECTIVE VIEW

02 ACTUAL PHOTO



Location:
TISSOT BOUTIQUE - SUNTEC CITY

TRANS -MATT
VS : W885 X H2880 MM
MS: W894 X H2924 MM

01 PERSPECTIVE VIEW



WHITE ARK LACQUERED METAL

REVERSE STICKER

HANGING VISUAL STICKER ON KAPALINE

WHITE ARK LACQUERED METAL

BLUE ARK LACQUERED METAL

CUTTING ON WHITE PMMA

STICKER ON FOREX BOARD

02 ACTUAL PHOTO



01 PERSPECTIVE VIEW

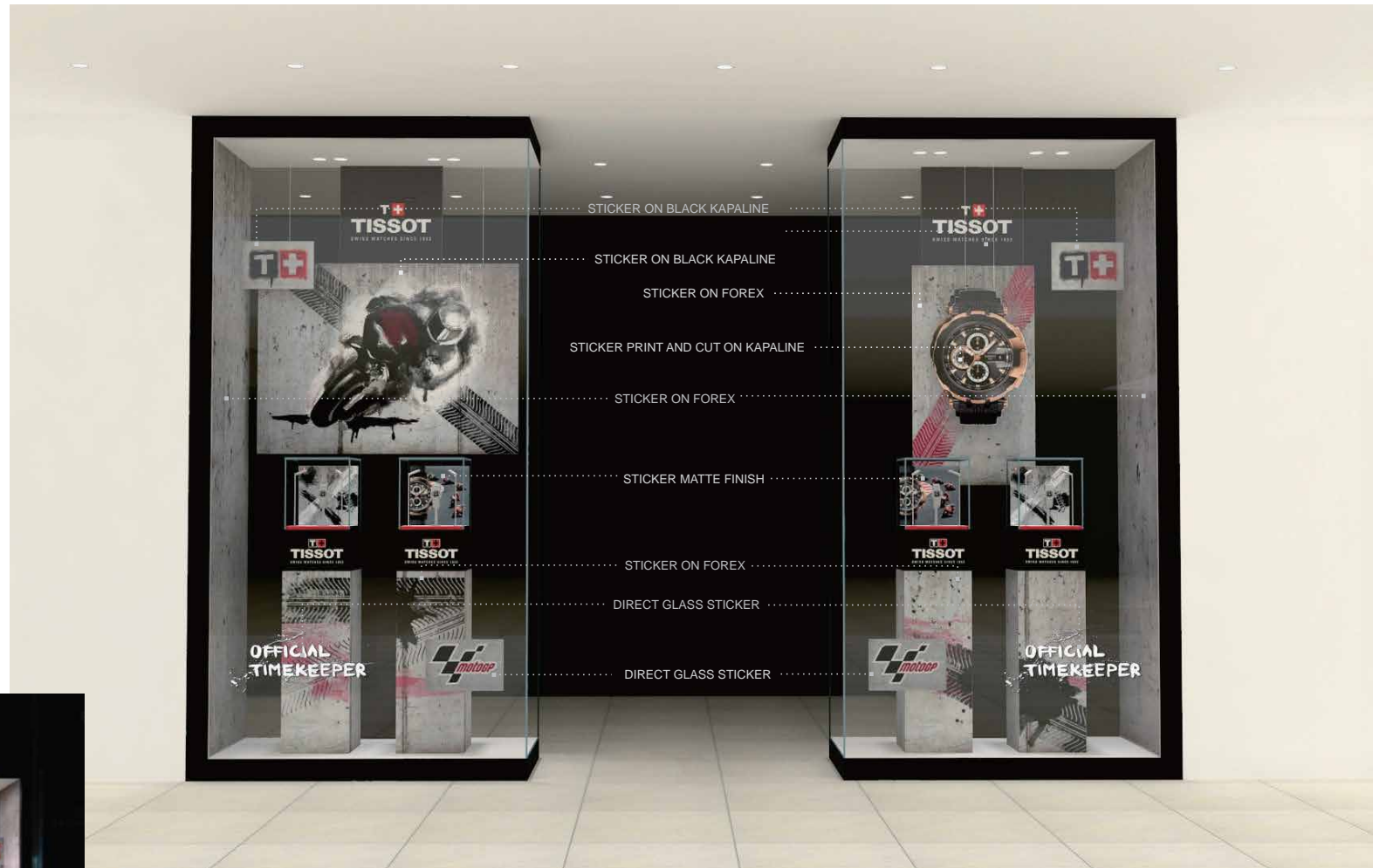

02 ACTUAL PHOTO



01 PERSPECTIVE VIEW



CUSHION AND 3D ELEMENT



3D DISPLAY ELEMENT

CUSHION ELEMENT

STICKER ON FOREX

02 ACTUAL PHOTO



01 PERSPECTIVE VIEW



CUSHION AND 3D ELEMENT



02 ACTUAL PHOTO



3D DISPLAY ELEMENT

CUSHION ELEMENT

STICKER ON FOREX

02 ACTUAL PHOTO

01 PERSPECTIVE VIEW



01 PERSPECTIVE VIEW

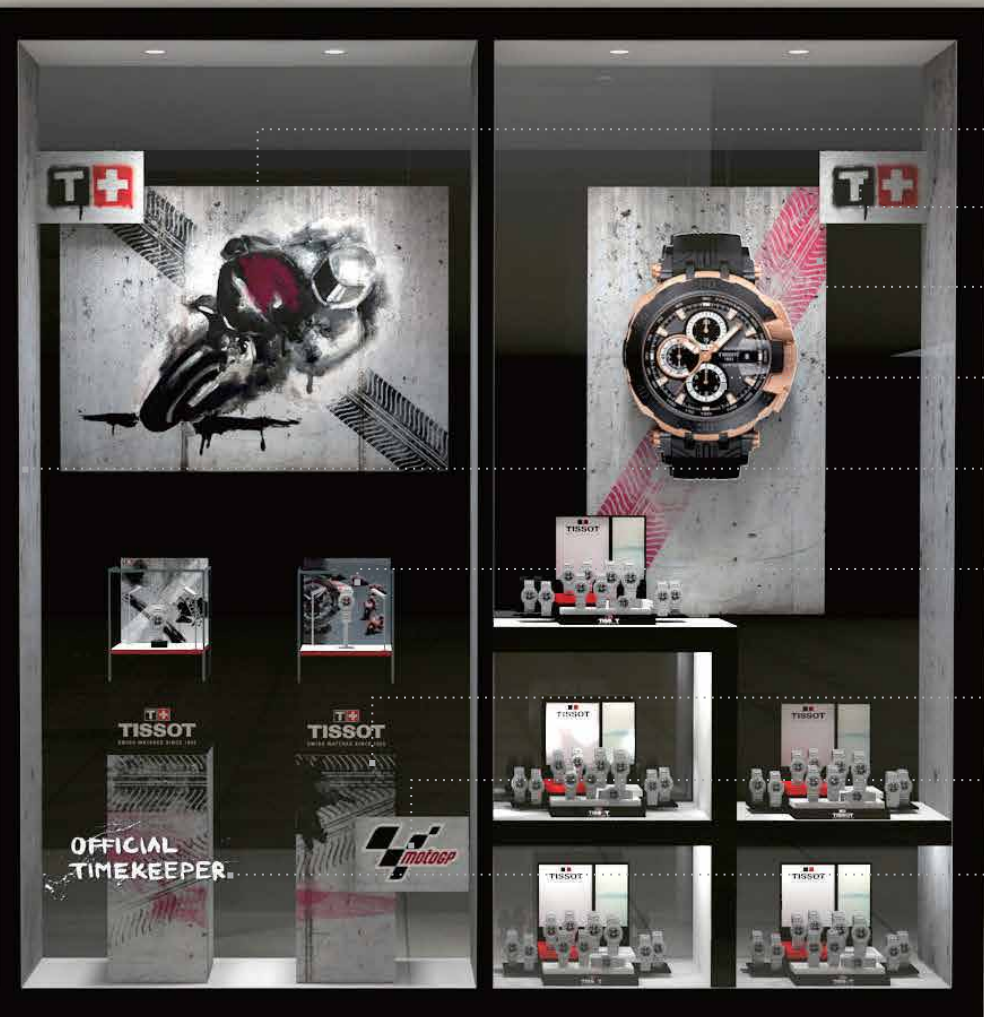

STICKER ON BLACK KAPALINE

STICKER ON BLACK KAPALINE

REVERSE GLASS STICKER

STICKER PRINT AND CUT
ON BLACK KAPALINE

STICKER ON FOREX
SIZE TBC

STICKER MATTE FINISH

STICKER ON FOREX

DIRECT GLASS STICKER

DIRECT GLASS STICKER

02 ACTUAL PHOTO





01 PERSPECTIVE VIEW





01 PERSPECTIVE VIEW



02 ACTUAL PHOTO







Glass Sticker

Item Displayer

Glass Sticker

Glass Sticker



Glass Sticker

Glass Sticker

WINDOW DISPLAY DESIGN

Location:
CORTINA BOUTIQUE - PARAGON

